



.....
Cheetah 36 Family:
.....

ST136403LW/LC
.....

.....
Product Manual, Volume 1
.....

.....
Cheetah 36 Family:
.....

ST136403LW/LC
.....

.....
Product Manual, Volume 1
.....

© 1999 Seagate Technology, Inc. All rights reserved
Publication number: 83329440, Rev. B
August 1999

Seagate, Seagate Technology, and the Seagate logo are registered trademarks of Seagate Technology, Inc. Cheetah, SeaFAX, SeaFONE, SeaBOARD, and SeaTDD are either trademarks or registered trademarks of Seagate Technology, Inc. or one of its subsidiaries. All other trademarks or registered trademarks are the property of their respective owners.

Seagate reserves the right to change, without notice, product offerings or specifications. No part of this publication may be reproduced in any form without written permission of Seagate Technology, Inc.

Revision status summary sheet

Revision	Date	Writer/Engineer	Sheets Affected
Rev. A	06/02/99	L. Newman/D. Rusch	1/1, v thru viii, 1-74. Class A Release.
Rev. B	07/20/99	L. Newman/D. Rusch	19 and 29.

Notice.

Product Manual 83329440 is Volume 1 of a two volume document with the SCSI Interface information in the Volume 2 SCSI Interface Product Manual, part number 77738479.

If you need the SCSI Interface information, order the Volume 2 Interface Manual, part number 77738479.

Table of Contents

1.0	Scope	1
2.0	Applicable standards and reference documentation	3
2.1	Standards	3
2.1.1	Electromagnetic compatibility	3
2.1.2	Electromagnetic susceptibility	3
2.2	Electromagnetic compliance	3
2.3	Reference documents	4
3.0	General description	5
3.1	Standard features	7
3.2	Media characteristics	7
3.3	Performance	7
3.4	Reliability	7
3.5	Unformatted and formatted capacities	8
3.6	Programmable drive capacity	8
3.7	Factory installed accessories	8
3.8	Options (factory installed)	8
3.9	Accessories (user installed)	8
4.0	Performance characteristics	9
4.1	Internal drive characteristics (transparent to user)	9
4.2	SCSI performance characteristics (visible to user)	9
4.2.1	Access time	9
4.2.2	Format command execution time (minutes)	9
4.2.3	Generalized performance characteristics	9
4.3	Start/stop time	10
4.4	Prefetch/multi-segmented cache control	10
4.5	Cache operation	10
4.5.1	Caching write data	11
4.5.2	Prefetch operation	12
5.0	Reliability specifications	13
5.1	Error rates	13
5.1.1	Environmental interference	13
5.1.2	Read errors	13
5.1.3	Write errors	13
5.1.4	Seek errors	13
5.2	Reliability and service	14
5.2.1	Mean time between failure	14
5.2.2	Field failure rate vs time	14
5.2.3	Preventive maintenance	15
5.2.4	Service life	15
5.2.5	Service philosophy	15
5.2.6	Service tools	15
5.2.7	Hot plugging Cheetah 36 disc drives	15
5.2.8	S.M.A.R.T.	16
5.2.9	Product warranty	17
6.0	Physical/electrical specifications	19
6.1	AC power requirements	19
6.2	DC power requirements	19
6.2.1	Conducted noise immunity	20
6.2.2	Power sequencing	20
6.2.3	12 V - Current profile	20
6.3	Power dissipation	22
6.4	Environmental limits	23

6.4.1	Temperature	23
6.4.2	Relative humidity	24
6.4.3	Effective altitude (sea level)	24
6.4.4	Shock and vibration	25
6.4.5	Air cleanliness	27
6.4.6	Acoustics	27
6.4.7	Electromagnetic susceptibility	27
6.5	Mechanical specifications	28
7.0	Defect and error management	31
7.1	Drive internal defects	31
7.2	Drive error recovery procedures	31
7.3	SCSI systems errors	32
8.0	Installation	33
8.1	Drive ID/option select header	33
8.1.1	Notes for Figures 12, 13, and 14.	36
8.1.2	Function description	37
8.2	Drive orientation	38
8.3	Cooling	38
8.3.1	Air flow	38
8.4	Drive mounting	39
8.5	Grounding	39
9.0	Interface requirements.	41
9.1	General description	41
9.2	SCSI interface messages supported	41
9.3	SCSI interface commands supported	42
9.3.1	Inquiry Vital Product data	45
9.3.2	Mode Sense data	46
9.4	SCSI bus conditions and miscellaneous features supported	48
9.5	Synchronous data transfer	49
9.5.1	Synchronous data transfer periods supported	49
9.5.2	REQ/ACK offset	49
9.6	Physical interface	49
9.6.1	DC cable and connector	49
9.6.2	SCSI interface physical description	51
9.6.3	SCSI interface cable requirements	51
9.6.4	Mating connectors	52
9.7	Electrical description	60
9.7.1	Multimode—SE and LVD alternatives	60
9.8	Terminator requirements	62
9.9	Terminator power	62
9.10	Disc drive SCSI timing	63
9.11	Drive activity LED	64
10.0	Seagate Technology support services.	65

List of Figures

Figure 1.	Cheetah 36 family drive (ST136403LW shown)	1
Figure 2.	Cheetah 36 family drive	6
Figure 3.	Typical Cheetah 36 family drive +12 V current profile	20
Figure 4.	Typical Cheetah 36 SCSI SE mode +5 V current profile	21
Figure 5.	Typical Cheetah 36 SCSI LVD mode +5 V current profile	21
Figure 6.	DC current and power vs. input/output operations per second (single-ended mode)	22
Figure 7.	DC current and power vs. input/output operations per second (LVD mode)	22
Figure 8.	Locations of PCBA components listed in Table 3	24
Figure 9.	Recommended mounting	26
Figure 10.	ST136403LW mounting configuration dimensions	28
Figure 11.	ST136403LC mounting configuration dimensions	29
Figure 12.	J6 jumper header	34
Figure 13.	J5 jumper header (on LW models only)	35
Figure 14.	J2 option select header	36
Figure 15.	Air flow (suggested)	38
Figure 16.	ST136403LW drive physical interface (68-pin J1 SCSI I/O connector)	50
Figure 17.	ST136403LC drive physical interface (80-pin J1 SCSI I/O connector)	50
Figure 18.	SCSI daisy chain interface cabling for LW drives	53
Figure 19.	Nonshielded 68 pin SCSI device connector used on LW drives	54
Figure 20.	Nonshielded 80 pin SCSI "SCA-2" connector, used on LC drives	55
Figure 21.	LVD output signals	61
Figure 22.	Typical SE-LVD alternative transmitter receiver circuits	61

1.0 Scope

This manual describes Seagate Technology®, Inc. Cheetah 36™ disc drives.

Cheetah 36 drives support the small computer system interface (SCSI) as described in the ANSI SCSI, SCSI-2, and SCSI-3 (Fast-20 and Fast-40) interface specifications to the extent described in this manual. The *SCSI Interface Product Manual* (part number 77738479) describes general SCSI interface characteristics of this and other families of Seagate drives.

From this point on in this product manual the reference to Cheetah 36 models is referred to as “the drive” unless references to individual models are necessary.

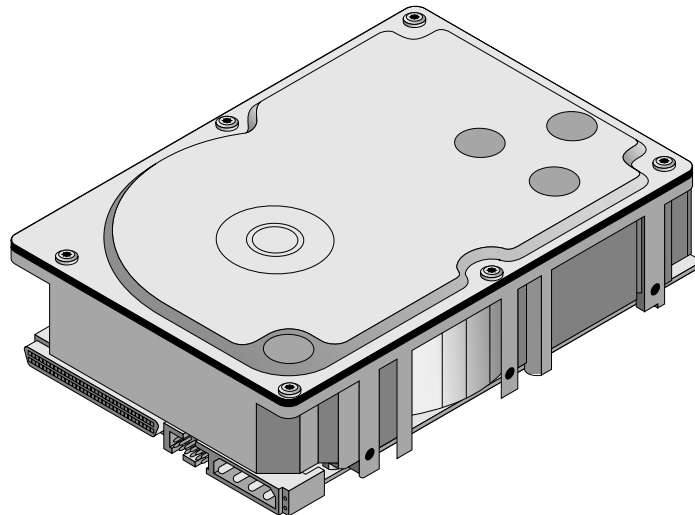

Figure 1. Cheetah 36 family drive (ST136403LW shown)

2.0 Applicable standards and reference documentation

The drive has been developed as a system peripheral to the highest standards of design and construction. The drive depends upon its host equipment to provide adequate power and environment in order to achieve optimum performance and compliance with applicable industry and governmental regulations. Special attention must be given in the areas of safety, power distribution, shielding, audible noise control, and temperature regulation. In particular, the drive must be securely mounted in order to guarantee the specified performance characteristics. Mounting by bottom holes must meet the requirements of Section 8.4.

2.1 Standards

The Cheetah 36 family complies with Seagate standards as noted in the appropriate sections of this Manual and the Seagate *SCSI Interface Product Manual*, part number 77738479 (Vol. 2).

The Cheetah 36 disc drive is a UL recognized component per UL1950, CSA certified to CSA C22.2 No. 950-M89, and VDE certified to VDE 0805 and EN60950.

2.1.1 Electromagnetic compatibility

The drive, as delivered, is designed for system integration and installation into a suitable enclosure prior to use. As such the drive is supplied as a subassembly and is not subject to Subpart B of Part 15 of the FCC Rules and Regulations nor the Radio Interference Regulations of the Canadian Department of Communications.

The design characteristics of the drive serve to minimize radiation when installed in an enclosure that provides reasonable shielding. As such, the drive is capable of meeting the Class B limits of the FCC Rules and Regulations of the Canadian Department of Communications when properly packaged. However, it is the user's responsibility to assure that the drive meets the appropriate EMI requirements in their system. Shielded I/O cables may be required if the enclosure does not provide adequate shielding. If the I/O cables are external to the enclosure, shielded cables should be used, with the shields grounded to the enclosure and to the host controller.

2.1.2 Electromagnetic susceptibility

As a component assembly, the drive is not required to meet any susceptibility performance requirements. It is the responsibility of those integrating the drive within their systems to perform those tests required and design their system to ensure that equipment operating in the same system as the drive or external to the system does not adversely affect the performance of the drive. See Section 5.1.1 and Table 2, DC power requirements.

2.2 Electromagnetic compliance

Seagate uses an independent laboratory to confirm compliance to the directives/standard(s) for CE Marking and C-Tick Marking. The drive was tested in a representative system for typical applications. The selected system represents the most popular characteristics for test platforms. The system configurations include:

- 486, Pentium, and PowerPC microprocessors
- 3.5-inch floppy disc drive
- Keyboard
- Monitor/display
- Printer
- External modem
- Mouse

Although the test system with this Seagate model complies to the directives/standard(s), we cannot guarantee that all systems will comply. The computer manufacturer or system integrator shall confirm EMC compliance and provide CE Marking and C-Tick Marking for their product.

Electromagnetic compliance for the European Union

If this model has the CE Marking it complies with the European Union requirements of the Electromagnetic Compatibility Directive 89/336/EEC of 03 May 1989 as amended by Directive 92/31/EEC of 28 April 1992 and Directive 93/68/EEC of 22 July 1993.

Australian C-Tick

If this model has the C-Tick Marking it complies with the Australia/New Zealand Standard AS/NZS3548 1995 and meets the Electromagnetic Compatibility (EMC) Framework requirements of Australia's Spectrum Management Agency (SMA).

2.3 Reference documents

<i>Cheetah 36 Installation Guide</i>	Seagate P/N 83329450
<i>SCSI Interface Product Manual</i>	Seagate P/N 77738479
ANSI small computer system interface (SCSI) document numbers:	
X3.131-1994	SCSI-2
X3.253-1995	SCSI-3 Parallel Interface
T10/1142D Rev. 14	SPI-2 (SCSI-3 Parallel Interface version 2)
SFF-8046 Specification for 80-pin connector for SCSI disk drives	
Package Test Specification	Seagate P/N 30190-001 (under 100 lb.)
Package Test Specification	Seagate P/N 30191-001 (over 100 lb.)
Specification, Acoustic Test Requirements, and Procedures	Seagate P/N 30553-001

In case of conflict between this document and any referenced document, this document takes precedence.

3.0 General description

Cheetah 36 drives combine dual stripe magnetoresistive (DSMR) heads, partial response/maximum likelihood (PRML) read channel electronics, embedded servo technology, and a wide Ultra2 SCSI interface to provide high performance, high capacity data storage for a variety of systems including engineering workstations, network servers, mainframes, and supercomputers.

Ultra SCSI and Ultra2 SCSI use negotiated transfer rates. These transfer rates will occur only if your host adapter supports these data transfer rates and is compatible with the required hardware requirements of the I/O circuit type. This drive also operates at SCSI-1 and SCSI-2 data transfer rates for backward compatibility with non-Ultra/Ultra2 SCSI host adapters.

Table 1 lists the features that differentiate the two Cheetah 36 models.

Table 1: Drive model number vs. differentiating features

Model number	Number of heads	I/O circuit type [1]	Number of I/O connector pins	Number of I/O data bus bits
ST136403LW	24	Single-ended (SE) and low voltage differential (LVD)	68	16
ST136403LC	24	Single-ended (SE) and low voltage differential (LVD)	80	16

[1] See Section 9.6 for details and definitions.

The drive records and recovers data on approximately 3.3-inch (84 mm) non-removeable discs.

The drive supports the Small Computer System Interface (SCSI) as described in the ANSI SCSI-2/SCSI-3 interface specifications to the extent described in this manual (volume 1), which defines the product performance characteristics of the Cheetah 36 family of drives, and the *SCSI Interface Product Manual* (volume 2), part number 77738479, which describes the general interface characteristics of this and other families of Seagate SCSI drives.

The drive's interface supports multiple initiators, disconnect/reconnect, self-configuring host software, and automatic features that relieve the host from the necessity of knowing the physical characteristics of the targets (logical block addressing is used).

The head and disc assembly (HDA) is sealed at the factory. Air circulates within the HDA through a non-replaceable filter to maintain a contamination-free HDA environment.

Refer to Figure 2 for an exploded view of the drive. This exploded view is for information only—never disassemble the HDA and do not attempt to service items in the sealed enclosure (heads, media, actuator, etc.) as this requires special facilities. The drive contains no replaceable parts. Opening the HDA voids your warranty.

Cheetah 36 drives use a dedicated landing zone at the innermost radius of the media to eliminate the possibility of destroying or degrading data by landing in the data zone. The drive automatically goes to the landing zone when power is removed.

An automatic shipping lock prevents potential damage to the heads and discs that results from movement during shipping and handling. The shipping lock automatically disengages when power is applied to the drive and the head load process begins.

Cheetah 36 drives decode track 0 location data from the servo data embedded on each surface to eliminate mechanical transducer adjustments and related reliability concerns.

A high-performance actuator assembly with a low-inertia, balanced, patented, straight-arm design provides excellent performance with minimal power dissipation.

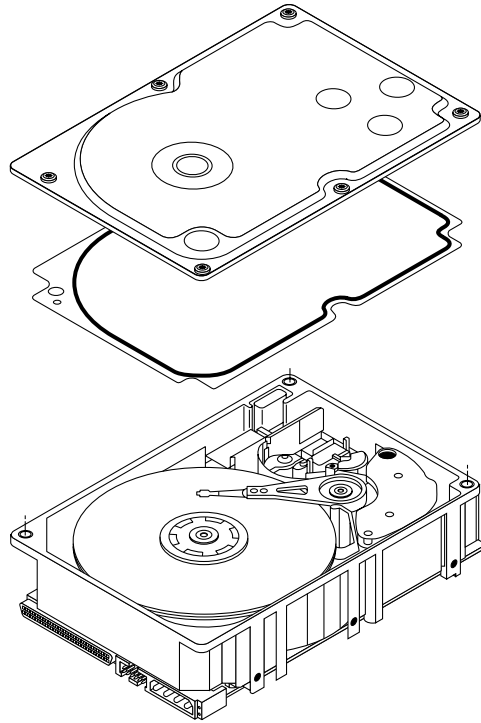

Figure 2. Cheetah 36 family drive

3.1 Standard features

The Cheetah 36 family has the following standard features:

- Integrated Ultra/Ultra2 SCSI controller
- Multimode SCSI drivers and receivers—single-ended (SE) and low voltage differential (LVD)
- 16 bit I/O data bus
- Asynchronous and synchronous data transfer protocol
- Firmware downloadable via SCSI interface
- Selectable even byte sector sizes from 512 to 4,096 bytes/sector
- Programmable sector reallocation scheme
- Flawed sector reallocation at format time
- Programmable auto write and read reallocation
- Reallocation of defects on command (post format)
- Enhanced ECC correction capability up to 185 bits
- Sealed head and disc assembly
- No preventative maintenance or adjustment required
- Dedicated head landing zone
- Embedded servo design
- Self diagnostics performed when power is applied to the drive
- 1:1 Interleave
- Zoned bit recording (ZBR)
- Vertical, horizontal, or top down mounting
- Dynamic spindle brake
- 1,024 kbyte data buffer (or 4,096 kbyte option)
- Hot plug compatibility (Section 9.6.4.2 lists proper host connector needed) for “LC” model drives
- SCAM (SCSI Configured Automatically) plug-n-play level 2 compliant, factory set to level 1

3.2 Media characteristics

The media used on the drive has a diameter of approximately 3.3 inches (84 mm). The aluminum substrate is coated with a thin film magnetic material, overcoated with a proprietary protective layer for improved durability and environmental protection.

3.3 Performance

- Supports industry standard Ultra2 SCSI interface
- Programmable multi-segmentable cache buffer (see Section 3.1)
- 10,016 RPM spindle. Average latency = 2.99 ms
- Command queuing of up to 64 commands
- Background processing of queue
- Supports start and stop commands (spindle stops spinning)

3.4 Reliability

- 1,000,000 hour MTBF
- LSI circuitry
- Balanced low mass rotary voice coil actuator
- Incorporates industry-standard Self-Monitoring, Analysis and Reporting Technology (S.M.A.R.T.)
- 5-year warranty

3.5 Unformatted and formatted capacities

Formatted capacity depends on the number of spare reallocation sectors reserved and the number of bytes per sector. The following table shows the standard OEM model capacities:

	Formatted data block size 512 bytes/sector [1]	Unformatted
ST136403	43D6720h (36.40 GB) [2]	43.2 GB

Notes.

- [1] Sector size selectable at format time. Users having the necessary equipment may modify the data block size before issuing a format command and obtain different formatted capacities than those listed. See Mode Select Command and Format Command in the *SCSI Interface Product Manual*, part number 77738479.
- [2] User available capacity depends on spare reallocation scheme selected, the number of data tracks per sparing zone, and the number of alternate sectors (LBAs) per sparing zone.

3.6 Programmable drive capacity

Using the Mode Select command, the drive can change its capacity to something less than maximum. See Table 5.2.1-13 in the *SCSI Interface Product Manual*, part number 77738479, Rev. H. Refer to the Parameter list block descriptor number of blocks field. A value of zero in the number of blocks field indicates that the drive shall not change the capacity it is currently formatted to have. A number in the number of blocks field that is less than the maximum number of LBAs changes the total drive capacity to the value in the block descriptor number of blocks field. A value greater than the maximum number of LBAs is rounded down to the maximum capacity.

3.7 Factory installed accessories

OEM Standard drives are shipped with the *Cheetah 36 Installation Guide*, part number 83329450 (unless otherwise specified). The factory also ships with the drive a small bag of jumper plugs used for the J2, J5, and J6 option select jumper headers.

3.8 Options (factory installed)

All customer requested options are incorporated during production or packaged at the manufacturing facility before shipping. Some of the options available are (not an exhaustive list of possible options):

- Other capacities can be ordered depending on sparing scheme and sector size requested.
- 4 Mbyte optional buffer size.
- Single unit shipping pack. The drive is normally shipped in bulk packaging to provide maximum protection against transit damage. Units shipped individually require additional protection as provided by the single unit shipping pack. Users planning single unit distribution should specify this option.
- The *Cheetah 36 Installation Guide*, part number 83329450, is usually included with each standard OEM drive shipped, but extra copies may be ordered.

3.9 Accessories (user installed)

The following accessories are available. All accessories may be installed in the field.

- Single unit shipping pack.

4.0 Performance characteristics

4.1 Internal drive characteristics (transparent to user)

ST136403		
Drive capacity	36.4	GByte (formatted, rounded off values)
Read/write heads	24	
Bytes/track	153,284–229,045	Bytes (average, rounded off values)
Bytes/surface	1,913	Mbytes (unformatted, rounded off values)
Tracks/surface (total)	9,801	Tracks (user accessible)
Tracks/inch	12,580	TPI
Peak bits/inch	252	KBPI
Internal data rate	179-313	Mbits/sec (variable with zone)
Disc rotational speed	10,016	r/min ($\pm 0.5\%$)
Average rotational latency	2.99	msec

4.2 SCSI performance characteristics (visible to user)

The values given in Section 4.2.1 apply to all models of the Cheetah 36 family unless otherwise specified. Refer to Section 9.10 and to the *SCSI Interface Product Manual*, part number 77738479, for additional timing details.

4.2.1 Access time [5]

				Including controller overhead (without disconnect) [1] [3]		Not including controller overhead (without disconnect) [1] [3]	
				Drive level		Drive level	
				Read	Write	Read	Write
				msec		msec	
Average	–	Typical	[2]	6.15	6.85	5.95	6.65
Single Track	–	Typical	[2]	0.8	1.1	0.6	0.9
Full Stroke	–	Typical	[2]	14.2	15.2	14.0	15.0

4.2.2 Format command execution time (minutes) [1]

ST136403	
Maximum (with verify)	120
Maximum (no verify)	60

4.2.3 Generalized performance characteristics

Minimum sector interleave 1 to 1

Data buffer transfer rate to/from disc media (one 512-byte sector):

Min.	[3]*	21.1	MByte/sec
Avg.	[3]	29.0	MByte/sec
Max.	[3]	36.8	MByte/sec

SCSI interface data transfer rate (asynchronous):

Maximum instantaneous one byte wide	5.0 Mbytes/sec [4]
Maximum instantaneous two bytes wide	10.0 Mbytes/sec [4]

Synchronous transfer rate for SCSI Fast-40 (Ultra2 SCSI):

In single-ended (SE) interface mode	5.0 to 40 Mbytes/sec
In low voltage differential (LVD) interface mode	5.0 to 80 Mbytes/sec

Sector Sizes:

Default	512 byte user data blocks
Variable	512 to 4,096 bytes per sector in even number of bytes per sector. If n (number of bytes per sector) is odd, then n-1 will be used.

Read/write consecutive sectors on a track	Yes
Flaw reallocation performance impact (for flaws reallocated at format time using the spare sectors per sparing zone reallocation scheme.)	Negligible
Average rotational latency	2.99 msec

Notes for Section 4.2.

- [1] Execution time measured from receipt of the last Byte of the Command Descriptor Block (CDB) to the request for a Status Byte Transfer to the Initiator (excluding connect/disconnect).
- [2] Typical access times are measured under nominal conditions of temperature, voltage, and horizontal orientation as measured on a representative sample of drives.
- [3] Assumes no errors and no sector has been relocated.
- [4] Assumes system ability to support the rates listed and no cable loss.
- [5] Access time = controller overhead + average seek time.
Access to data = controller overhead + average seek time + latency time.

4.3 Start/stop time

After DC power at nominal voltage has been applied, the drive becomes ready within 30 seconds if the Motor Start Option is disabled (i.e. the motor starts as soon as the power has been applied). If a recoverable error condition is detected during the start sequence, the drive executes a recovery procedure which may cause the time to become ready to exceed 30 seconds. During spin up to ready time the drive responds to some commands over the SCSI interface in less than 3 seconds after application of power. Stop time is less than 30 seconds from removal of DC power.

If the Motor Start Option is enabled, the internal controller accepts the commands listed in the SCSI Interface Product Manual less than 3 seconds after DC power has been applied. After the Motor Start Command has been received the drive becomes ready for normal operations within 30 seconds typically (excluding an error recovery procedure). The Motor Start Command can also be used to command the drive to stop the spindle (see *SCSI Interface Product Manual*, part number 77738479).

There is no power control switch on the drive.

4.4 Prefetch/multi-segmented cache control

The drive provides prefetch (read look-ahead) and multi-segmented cache control algorithms that in many cases can enhance system performance. "Cache" as used herein refers to the drive buffer storage space when it is used in cache operations. To select prefetch and cache features the host sends the Mode Select command with the proper values in the applicable bytes in Mode Page 08h (see *SCSI Interface Product Manual*, part number 77738479). Prefetch and cache operation are independent features from the standpoint that each is enabled and disabled independently via the Mode Select command. However, in actual operation the prefetch feature overlaps cache operation somewhat as is noted in Section 4.5.1 and 4.5.2.

All default cache and prefetch Mode parameter values (Mode Page 08h) for standard OEM versions of this drive family are given in Tables 8.

4.5 Cache operation

In general, 840 Kbytes (3,600 kbytes of the 4,096 kbytes on units with this option) of the physical buffer space in the drive can be used as storage space for cache operations. The buffer can be divided into logical segments (Mode Select Page 08h, byte 13) from which data is read and to which data is written. The drive maintains a table of logical block disk medium addresses of the data stored in each segment of the buffer. If cache operation is enabled (RCD bit = 0 in Mode Page 08h, byte 2, bit 0. See *SCSI Interface Product Manual*, part number 77738479), data requested by the host with a Read command is retrieved from the buffer (if it is there), before any disc access is initiated. If cache operation is not enabled, the buffer (still segmented with required

number of segments) is still used, but only as circular buffer segments during disc medium read operations (disregarding Prefetch operation for the moment). That is, the drive does not check in the buffer segments for the requested read data, but goes directly to the medium to retrieve it. The retrieved data merely passes through some buffer segment on the way to the host. On a cache miss, all data transfers to the host are in accordance with buffer-full ratio rules. On a cache hit the drive ignores the buffer-full ratio rules. See explanations associated with Mode page 02h (disconnect/reconnect control) in the *SCSI Interface Product Manual*.

The following is a simplified description of a read operation with cache operation enabled:

Case A - A Read command is received and the first logical block (LB) is already in cache:

1. Drive transfers to the initiator the first LB requested plus all subsequent contiguous LBs that are already in the cache. This data may be in multiple segments.
2. When the requested LB is reached that is not in any cache segment, the drive fetches it and any remaining requested LBs from the disc and puts them in a segment of the cache. The drive transfers the remaining requested LBs from the cache to the host in accordance with the disconnect/reconnect specification mentioned above.
3. If the prefetch feature is enabled, refer to Section 4.5.2 for operation from this point.

Case B - A Read command requests data, the first LB of which is not in any segment of the cache:

1. The drive fetches the requested LBs from the disc and transfers them into a segment, and from there to the host in accordance with the disconnect/reconnect specification referred to in case A.
2. If the prefetch feature is enabled, refer to Section 4.5.2 for operation from this point.

Each buffer segment is actually a self-contained circular storage (wrap-around occurs), the length of which is an integer number of disc medium sectors. The wrap-around capability of the individual segments greatly enhances the buffer's overall performance as a cache storage, allowing a wide range of user selectable configurations, which includes their use in the prefetch operation (if enabled), even when cache operation is disabled (see Section 4.5.2). The number of segments may be selected using the Mode Select command, but the size can not be directly selected. Size is selected only as a by-product of selecting the segment number specification. The size in Kbytes of each segment is not reported by the Mode Sense command page 08h, bytes 14 and 15. The value 0XFFFF is always reported. If a size specification is sent by the host in a Mode Select command (bytes 14 and 15) no new segment size is set up by the drive, and if the STRICT bit in Mode page 00h (byte 2, bit 1) is set to one, the drive responds as it does for any attempt to change unchangeable parameters (see *SCSI Interface Product Manual*, part number 77738479). The drive supports operation of any integer number of segments from 1 to 16. Default is three segments.

4.5.1 Caching write data

Write caching is a write operation by the drive that makes use of a drive buffer storage area where the data to be written to the medium is stored in one or more segments while the drive performs the write command.

If read caching is enabled (RCD=0), then data written to the medium is retained in the cache to be made available for future read cache hits. The same buffer space and segmentation is used as set up for read functions. The buffer segmentation scheme is set up or changed independently, having nothing to do with the state of RCD. When a write command is issued, if RCD=0, the cache is first checked to see if any logical blocks that are to be written are already stored in the cache from a previous read or write command. If there are, the respective cache segments are cleared. The new data is cached for subsequent Read commands.

If the number of write data logical blocks exceeds the size of the segment being written into, when the end of the segment is reached, the data is written into the beginning of the same cache segment, overwriting the data that was written there at the beginning of the operation. However, the drive does not overwrite data that has not yet been written to the medium.

If write caching is enabled (WCE=1), then the drive may return GOOD status on a write command after the data has been transferred into the cache, but before the data has been written to the medium. If an error occurs while writing the data to the medium, and GOOD status has already been returned, a deferred error will be generated.

The Synchronize Cache command may be used to force the drive to write all cached write data to the medium. Upon completion of a Synchronize Cache command, all data received from previous write commands will have been written to the medium.

Tables 8 show Mode default settings for the drives.

4.5.2 Prefetch operation

If the Prefetch feature is enabled, data in contiguous logical blocks on the disc immediately beyond that which was requested by a Read command can be retrieved and stored in the buffer for immediate transfer from the buffer to the host on subsequent Read commands that request those logical blocks (this is true even if cache operation is disabled). Though the prefetch operation uses the buffer as a cache, finding the requested data in the buffer is a prefetch hit, not a cache operation hit. Prefetch is enabled using Mode Select page 08h, byte 12, bit 5 (Disable Read Ahead - DRA bit). DRA bit = 0 enables prefetch. Since data that is prefetched replaces data already in some buffer segment(s), the host can limit the amount of prefetch data to optimize system performance. The max prefetch field (bytes 8 and 9) limits the amount of prefetch. The drive does not use the Prefetch Ceiling field (bytes 10 and 11).

During a prefetch operation, the drive crosses a cylinder boundary to fetch more data only if the Discontinuity (DISC) bit is set to one in bit 4 of byte 2 of Mode parameters page 08h.

Whenever prefetch (read look-ahead) is enabled (enabled by DRA = 0), it operates under the control of ARLA (Adaptive Read Look-Ahead). If the host uses software interleave, ARLA enables prefetch of contiguous blocks from the disc when it senses that a prefetch hit will likely occur, even if two consecutive read operations were not for physically contiguous blocks of data (e.g. "software interleave"). ARLA disables prefetch when it decides that a prefetch hit will not likely occur. If the host is not using software interleave, and if two sequential read operations are not for contiguous blocks of data, ARLA disables prefetch, but as long as sequential read operations request contiguous blocks of data, ARLA keeps prefetch enabled.

5.0 Reliability specifications

The following reliability specifications assume correct host/drive operational interface, including all interface timings, power supply voltages, environmental requirements and drive mounting constraints (see Section 8.4).

Seek Errors	Less than 10 in 10^8 seeks
Read Error Rates [1]	
Recovered Data	Less than 10 errors in 10^{12} bits transferred (OEM default settings)
Unrecovered Data	Less than 1 sector in 10^{15} bits transferred (OEM default settings)
Miscorrected Data	Less than 1 sector in 10^{21} bits transferred
MTBF	1,000,000 hours
Service Life	5 years
Preventive Maintenance	None required

Note.

[1] Error rate specified with automatic retries and data correction with ECC enabled and all flaws reallocated.

5.1 Error rates

The error rates stated in this specification assume the following:

- The drive is operated per this specification using DC power as defined in this manual (see Section 6.2).
- The drive has been formatted with the SCSI FORMAT command.
- Errors caused by media defects or host system failures are excluded from error rate computations. Refer to Section 3.2, "Media Characteristics."
- Assume random data.

5.1.1 Environmental interference

When evaluating systems operation under conditions of Electromagnetic Interference (EMI), the performance of the drive within the system shall be considered acceptable if the drive does not generate an unrecoverable condition.

An unrecoverable error, or unrecoverable condition, is defined as one that:

- Is not detected and corrected by the drive itself;
- Is not capable of being detected from the error or fault status provided through the drive or SCSI interface; or
- Is not capable of being recovered by normal drive or system recovery procedures without operator intervention.

5.1.2 Read errors

Before determination or measurement of read error rates:

- The data that is to be used for measurement of read error rates must be verified as being written correctly on the media.
- All media defect induced errors must be excluded from error rate calculations.

5.1.3 Write errors

Write errors can occur as a result of media defects, environmental interference, or equipment malfunction. Therefore, write errors are not predictable as a function of the number of bits passed.

If an unrecoverable write error occurs because of an equipment malfunction in the drive, the error is classified as a failure affecting MTBF. Unrecoverable write errors are those which cannot be corrected within two attempts at writing the record with a read verify after each attempt (excluding media defects).

5.1.4 Seek errors

A seek error is defined as a failure of the drive to position the heads to the addressed track. There shall be no more than ten recoverable seek errors in 10^8 physical seek operations. After detecting an initial seek error, the drive automatically performs an error recovery process. If the error recovery process fails, a seek positioning error (15h) is reported with a Medium error (3h) or Hardware error (4h) reported in the Sense Key. This is an

unrecoverable seek error. Unrecoverable seek errors are classified as failures for MTBF calculations. Refer to Section 5.1.1.2 of the *SCSI Interface Product Manual*, part number 77738479, for Request Sense information.

5.2 Reliability and service

You can enhance the reliability of Cheetah 36 disc drives by ensuring that the drive receives adequate cooling. Section 6.0 provides temperature measurements and other information that may be used to enhance the service life of the drive. Section 8.3.1 provides recommended air-flow information.

5.2.1 Mean time between failure

The production disc drive shall achieve an MTBF of 1,000,000 hours when operated in an environment that ensures the case temperatures specified in Section 6.4.1, Table 3 are not exceeded. Short-term excursions up to the specification limits of the operating environment will not affect MTBF performance. Continual or sustained operation at case temperatures above the values shown in Table 3 may degrade product reliability.

The MTBF target is specified as device power-on hours (POH) for all drives in service per failure.

$$\text{MTBF per measurement period} = \frac{\text{Estimated power-on operating hours in the period}}{\text{Number of drive failures in the period}}$$

Estimated power-on operation hours means power-up hours per disc drive times the total number of disc drives in service. Each disc drive shall have accumulated at least nine months of operation. Data shall be calculated on a rolling average base for a minimum period of six months.

MTBF is based on the following assumptions:

- 8,760 power-on hours per year.
- 250 average on/off cycles per year.
- Operations at nominal voltages.
- Systems will provide adequate cooling to ensure the case temperatures specified in Section 6.4.1 are not exceeded.

Drive failure means any stoppage or failure to meet defined specifications caused by drive malfunction.

A S.M.A.R.T. predictive failure indicates that the drive is deteriorating to an imminent failure and is considered an MTBF hit.

5.2.2 Field failure rate vs time

The expected field failure rate is listed below. Drive utilization will vary. An estimated range of utilization is:

- 720 power-on hours (POH) per month.
- 250 on/off cycles per year.
- Read/seek/write operation 20% of power-on hours.
- Systems will provide adequate cooling to ensure the case temperatures specified in Section 6.4.1 are not exceeded.

Month 1	2,364 PPM
Month 2	1,422 PPM
Month 3	1,403 PPM
Month 4	1,391 PPM
Month 5	1,317 PPM
Month 6	1,255 PPM
Month 7	1,162 PPM
Month 8+	1,025 PPM

Failure rate is calculated as follows:

- No system-induced failures are counted
- Based on 1,000,000 MTBF and 720 power-on hours per month
- Month 1's rate includes a 300 PPM installation failure

5.2.3 Preventive maintenance

No routine scheduled preventive maintenance shall be required.

5.2.4 Service life

The drive shall have a useful service life of five years. Depot repair or replacement of major parts is permitted during the lifetime (see Section 5.2.5).

5.2.5 Service philosophy

Special equipment is required to repair the drive HDA. In order to achieve the above service life, repairs must be performed only at a properly equipped and staffed service and repair facility. Troubleshooting and repair of PCBs in the field is not recommended, because of the extensive diagnostic equipment required for effective servicing. Also, there are no spare parts available for this drive. Drive warranty is voided if the HDA is opened.

5.2.6 Service tools

No special tools are required for site installation or recommended for site maintenance. Refer to Section 5.2.5. The depot repair philosophy of the drive precludes the necessity for special tools. Field repair of the drive is not practical since there are no user purchasable parts in the drive.

5.2.7 Hot plugging Cheetah 36 disc drives

The ANSI SPI-2 (T10/1142D) document defines the physical requirements for removal and insertion of SCSI devices on the SCSI bus. Four cases are addressed. The cases are differentiated by the state of the SCSI bus when the removal or insertion occurs.

Case 1 - All bus devices powered off during removal or insertion

Case 2 - RST signal asserted continuously during removal or insertion

Case 3 - Current I/O processes not allowed during insertion or removal

Case 4 - Current I/O process allowed during insertion or removal, except on the device being changed

Seagate Cheetah 36 disc drives support all four hot plugging cases. Provision shall be made by the system such that a device being inserted makes power and ground connections prior to the connection of any device signal contact to the bus. A device being removed shall maintain power and ground connections after the disconnection of any device signal contact from the bus (see SFF-8046, SCA-2 specification).

It is the responsibility of the systems integrator to assure that no hazards from temperature, energy, voltage, or ESD potential are presented during the hot connect/disconnect operation.

All I/O processes for the SCSI device being inserted or removed shall be quiescent. All SCSI devices on the bus shall have receivers that conform to the SPI-2 standard.

If the device being hot plugged uses single-ended (SE) drivers and the bus is currently operating in low voltage differential (LVD) mode, then all I/O processes for all devices on the bus must be completed, and the bus quiesced, before attempting to hot plug. Following the insertion of the newly installed device, the SCSI host adapter must issue a Bus Reset, followed by a synchronous transfer negotiation. Failure to perform the SCSI Bus Reset could result in erroneous bus operations.

The SCSI bus termination and termination power source shall be external to the device being inserted or removed.

End users should not mix devices with high voltage differential (HVD) drivers and receivers and devices with SE, LVD, or multimode drivers and receivers on the same SCSI bus since the common mode voltages in the HVD environment may not be controlled to safe levels for SE and LVD devices (see ANSI SPI-2).

The disc drive spindle must come to a complete stop prior to completely removing the drive from the cabinet chassis. Use of the Stop Spindle command or partial withdrawal of the drive, enough to be disconnected from the power source, prior to removal are methods for insuring that this requirement is met. During drive insertion, care should be taken to avoid exceeding the limits stated in Section 6.4.4, "Shock and vibration" in this manual.

5.2.8 S.M.A.R.T.

S.M.A.R.T. is an acronym for Self-Monitoring Analysis and Reporting Technology. This technology is intended to recognize conditions that indicate a drive failure and is designed to provide sufficient warning of a failure to allow data back-up before an actual failure occurs.

Note. The firmware will monitor specific attributes for degradation over time but cannot predict instantaneous drive failures.

Each attribute has been selected to monitor a specific set of failure conditions in the operating performance of the drive, and the thresholds are optimized to minimize “false” and “failed” predictions.

Controlling S.M.A.R.T.

The operating mode of S.M.A.R.T. is controlled by the DEXCPT bit and the PERF bit of the “Informational Exceptions Control Mode Page” (1Ch). The DEXCPT bit is used to enable or disable the S.M.A.R.T. process. Setting the DEXCPT bit will disable all S.M.A.R.T. functions. When enabled, S.M.A.R.T. will collect on-line data as the drive performs normal read/write operations. When the PERF bit is set, the drive is considered to be in “On-line Mode Only” and will not perform off-line functions.

The process of measuring off-line attributes and saving data can be forced by the RTZ command. Forcing S.M.A.R.T. will reset the timer so that the next scheduled interrupt will be two hours.

The drive can be interrogated by the host to determine the time remaining before the next scheduled measurement and data logging process will occur. This is accomplished by a log sense command to log page 0x3E. The purpose is to allow the customer to control when S.M.A.R.T. interruptions occur. As described above, forcing S.M.A.R.T. by the Rezero Unit command will reset the timer.

Performance impact

S.M.A.R.T. attribute data will be saved to the disc for the purpose of recreating the events that caused a predictive failure. The drive will measure and save parameters once every two hours subject to an idle period on the SCSI bus. The process of measuring off-line attribute data and saving data to the disc is uninterruptable and the maximum delay is summarized below:

Maximum processing delay

	On-line only delay DEXCPT = 0, PERF = 1	Fully enabled delay DEXCPT = 0, PERF = 0
S.M.A.R.T. delay times	50 milliseconds	300 milliseconds

Reporting control

Reporting is controlled in the Informational Exceptions Control Page (1Ch). Subject to the reporting method, the firmware will issue a 01-5D00 sense code to the host. The error code is preserved through bus resets and power cycles.

Determining rate

S.M.A.R.T. monitors the rate at which errors occur and signals a predictive failure if the rate of degraded error rate increases to an unacceptable level. To determine rate, error events are logged and compared to the number of total operations for a given attribute. The interval defines the number of operations over which to measure the rate. The counter that keeps track of the current number of operations is referred to as the Interval Counter.

S.M.A.R.T. measures error rate, hence for each attribute the occurrence of an error is recorded. A counter keeps track of the number of errors for the current interval. This counter is referred to as the Failure Counter.

Error rate is simply the number of errors per operation. The algorithm that S.M.A.R.T. uses to record rates of error is to set thresholds for the number of errors and the interval. If the number of errors exceeds the threshold before the interval expires, then the error rate is considered to be unacceptable. If the number of errors does not exceed the threshold before the interval expires, then the error rate is considered to be acceptable. In either case, the interval and failure counters are reset and the process starts over.

Predictive failures

S.M.A.R.T. signals predictive failures when the drive is performing unacceptably for a period of time. The firmware keeps a running count of the number of times the error rate for each attribute is unacceptable. To accomplish this, a counter is incremented whenever the error rate is unacceptable and decremented (not to exceed zero) whenever the error rate is acceptable. Should the counter continually be incremented such that it reaches the predictive threshold, a predictive failure is signaled. This counter is referred to as the Failure History Counter. There is a separate Failure History Counter for each attribute.

5.2.9 Product warranty

Beginning on the date of shipment to customer and continuing for a period of five years, Seagate warrants that each product (including components and subassemblies) or spare part that fails to function properly under normal use due to defect in materials or workmanship or due to nonconformance to the applicable specifications will be repaired or replaced, at Seagate's option and at no charge to customer, if returned by customer at customer's expense to Seagate's designated facility in accordance with Seagate's warranty procedure. Seagate will pay for transporting the repair or replacement item to customer. For more detailed warranty information refer to the Standard terms and conditions of Purchase for Seagate products.

Shipping

When transporting or shipping a drive, a Seagate approved container must be used. Keep your original box. They are easily identified by the Seagate-approved package label. Shipping a drive in a non-approved container voids the drive warranty.

Seagate repair centers may refuse receipt of components improperly packaged or obviously damaged in transit. Contact your Authorized Seagate Distributor to purchase additional boxes. Seagate recommends shipping by an air-ride carrier experienced in handling computer equipment.

Product repair and return information

Seagate customer service centers are the only facilities authorized to service Seagate drives. Seagate does not sanction any third-party repair facilities. Any unauthorized repair or tampering with the factory-seal voids the warranty.

6.0 Physical/electrical specifications

This section provides information relating to the physical and electrical characteristics of the Cheetah 36 drive.

6.1 AC power requirements

None.

6.2 DC power requirements

The voltage and current requirements for a single drive are shown in the following table. Values indicated apply at the drive power connector. The table shows current values in Amperes.

Table 2: DC power requirements

	Notes	SE mode		LVD mode	
		ST136403		ST136403	
		+5 V	+12 V	+5 V	+12 V
Voltage		+5 V	+12 V	+5 V	+12 V
Regulation	[5]	±5%	±5%[2]	±5%	±5%[2]
Average idle current DC \bar{X}	[1][7]	0.75	0.99	0.77	0.99
Maximum starting current (peak DC) DC	[3]	0.89	2.4	0.92	2.4
(peak AC) AC	[3]	1.1	3.4	1.1	3.4
Delayed motor start (max) DC	[1][4]	0.71	0.02	0.75	0.02
Peak operating current DC \bar{X}	[1][6]	0.83	1.5	0.87	1.5
Maximum DC	[1]	0.89	1.6	0.95	1.6
Maximum (peak) DC		1.14	3.2	1.4	3.2

- [1] Measured with average reading DC ammeter or equivalent sampling scope. Instantaneous current peaks will exceed these values. Power supply at nominal voltage.
- [2] For +12 V, a –10% tolerance is permissible during initial start of spindle, and must return to ±5% before 10,000 rpm is reached. The ±5% must be maintained after the drive signifies that its power-up sequence has been completed and that the drive is able to accept selection by the host initiator.
- [3] See +12 V current profile in Figure 3.
- [4] This condition occurs when the Motor Start Option is enabled and the drive has not yet received a Start Motor command.
- [5] See Section 6.2.1 “Conducted Noise Immunity.” Specified voltage tolerance is inclusive of ripple, noise, and transient response.
- [6] Operating condition is defined as random 8 block reads at 185 I/Os per second. Current and power specified at nominal voltages. Increasing +5 volt supply by +5% increases 5 volt current by <0.5%. Decreasing +12 volt supply by 5% increases +12 volt current by 3%.
- [7] During idle, the drive heads are relocated every 60 seconds to a random location within the band from track zero to one-fourth of maximum track.

General Notes from Table 2:

- Minimum current loading for each supply voltage is not less than 1.2% of the maximum operating current shown.
- The +5 and +12 volt supplies shall employ separate ground returns.
- Where power is provided to multiple drives from a common supply, careful consideration for individual drive power requirements should be noted. Where multiple units are powered on simultaneously, the peak starting current must be available to each device.
- Parameters, other than spindle start, are measured after a 10-minute warm up.
- No terminator power.

6.2.1 Conducted noise immunity

Noise is specified as a periodic and random distribution of frequencies covering a band from DC to 10 MHz. Maximum allowed noise values given below are peak to peak measurements and apply at the drive power connector.

+5 V = 150 mV pp from 0 to 100 kHz and 100 mV pp from 100 kHz to 10 MHz.

+12 V = 150 mV pp from 0 to 100 kHz and 100 mV pp from 100 kHz to 10 MHz.

6.2.2 Power sequencing

The drive does not require power sequencing. The drive protects against inadvertent writing during power-up and down. Daisy-chain operation requires that power be maintained on the SCSI bus terminator to ensure proper termination of the peripheral I/O cables. To automatically delay motor start based on the target ID (SCSI ID) enable the Delay Motor Start option and disable the Enable Motor Start option on the J2 connector. See Section 8.1 for pin selection information. To delay the motor until the drive receives a Start Unit command, enable the Enable Remote Motor Start option on the J2 connector.

6.2.3 12 V - Current profile

Figure 3 identifies the drive +12 V current profile. The current during the various times is as shown:

- T0 - Power is applied to the drive.
- T1 - Controller self tests are performed.
- T2 - Spindle begins to accelerate under current limiting after performing drive internal diagnostics. See Note 1 of Table 2.
- T3 - The spindle is up to speed and the head-arm restraint is unlocked.
- T4 - The adaptive servo calibration sequence is performed.
- T5 - Calibration is complete and drive is ready for reading and writing.

Note. All times and currents are typical. See Table 2 for maximum current requirements.

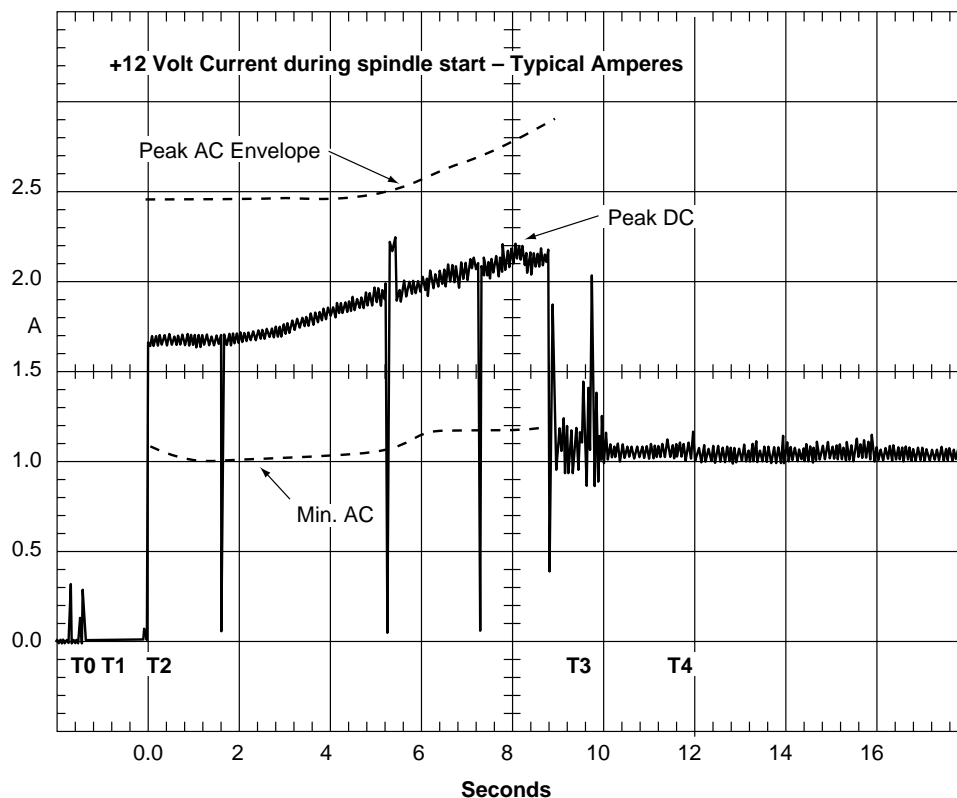

Figure 3. Typical Cheetah 36 family drive +12 V current profile

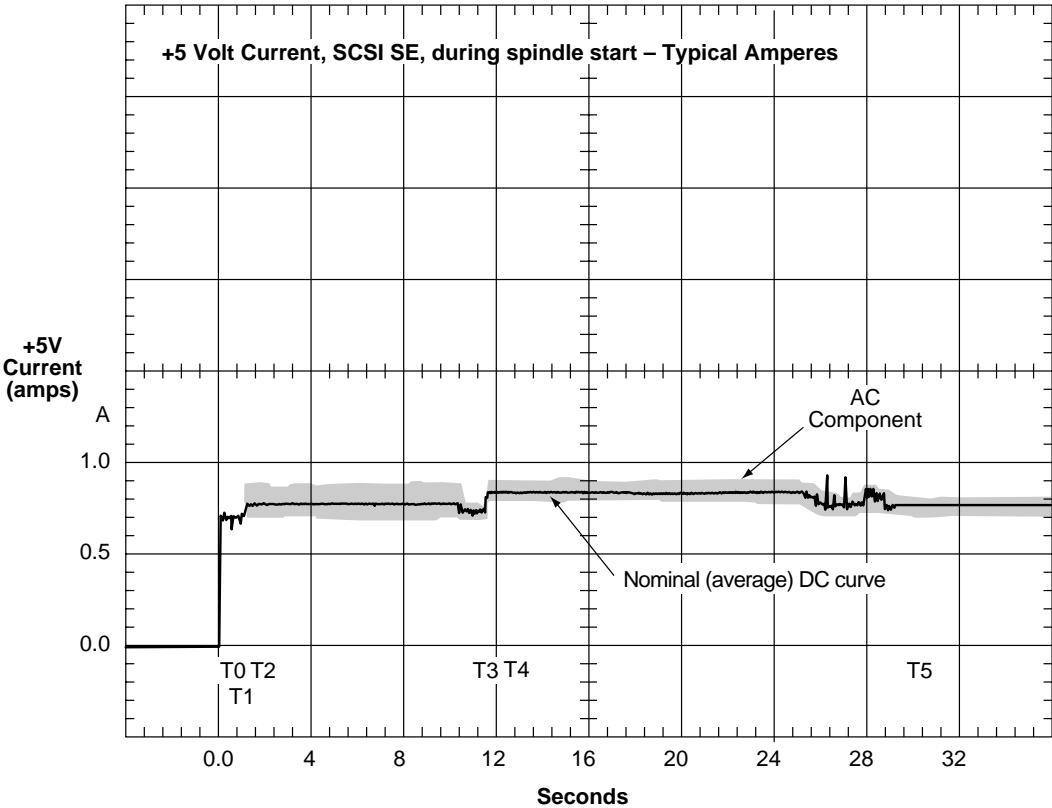

Figure 4. Typical Cheetah 36 SCSI SE mode +5 V current profile

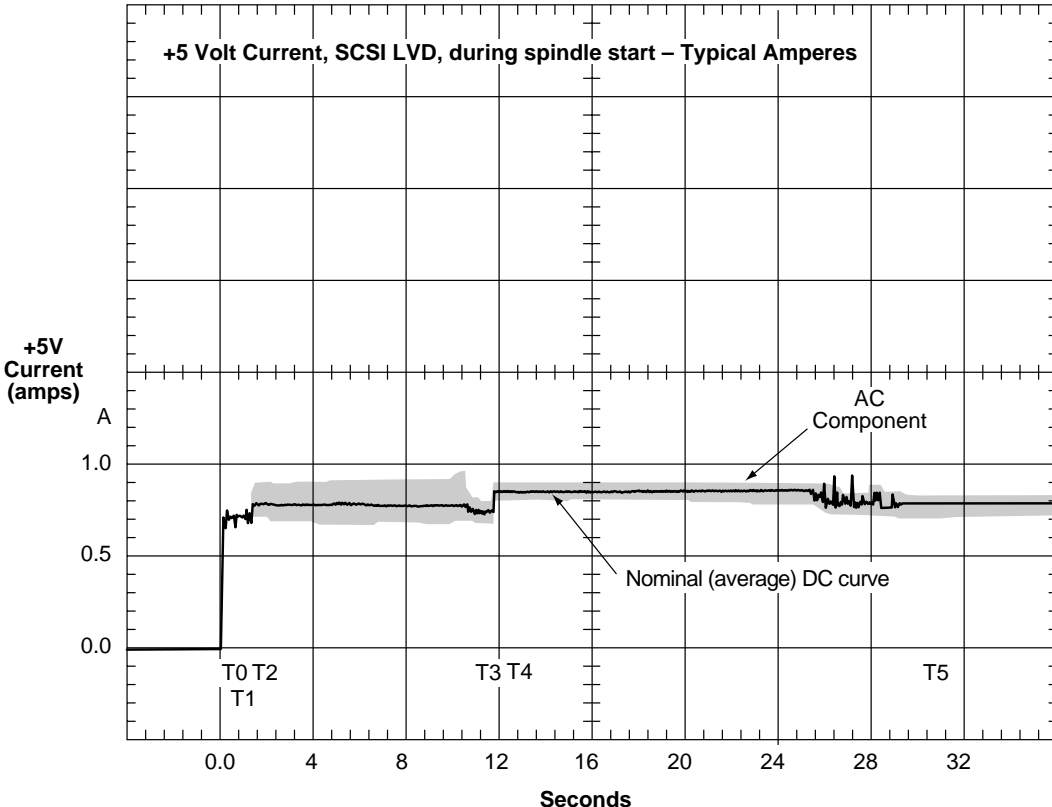

Figure 5. Typical Cheetah 36 SCSI LVD mode +5 V current profile

6.3 Power dissipation

For drives using single-ended interface circuits, typical power dissipation under idle conditions is 15.63 watts (53.3 BTUs per hour).

For drives using low voltage differential interface circuits, typical power dissipation under idle conditions is 15.73 watts (53.7 BTUs per hour).

To obtain operating power for typical random read operations, refer to the following two I/O rate curves (see figures 6 and 7). Locate the typical I/O rate for a drive in your system on the horizontal axis and read the corresponding +5 volt current, +12 volts current, and total watts on the vertical axis. To calculate BTUs per hour, multiply watts by 3.4123.

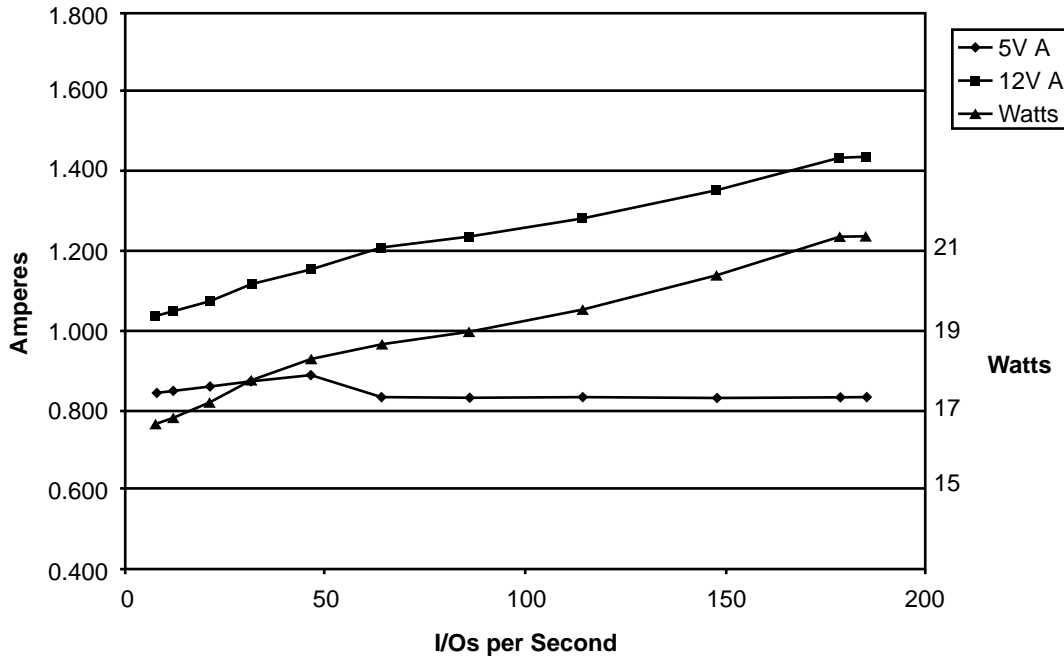

Figure 6. DC current and power vs. input/output operations per second (single-ended mode)

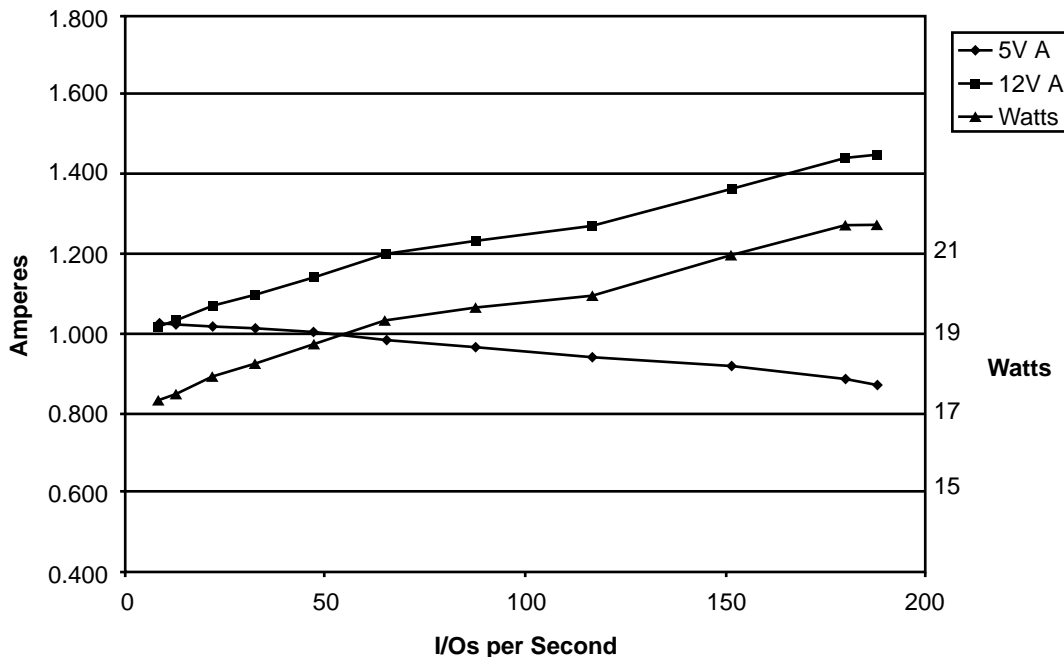

Figure 7. DC current and power vs. input/output operations per second (LVD mode)

6.4 Environmental limits

Temperature and humidity values experienced by the drive must be such that condensation does not occur on any drive part. Altitude and atmospheric pressure specifications are referenced to a standard day at 58.7°F (14.8°C). Maximum wet bulb temperature is 82°F (28°C).

6.4.1 Temperature

a. Operating

With cooling designed to maintain the case temperatures of Table 3, the drive meets all specifications over a 41°F to 122°F (5°C to 50°C) drive ambient temperature range with a maximum temperature gradient of 36°F (20°C) per hour. The enclosure for the drive should be designed such that the temperatures at the locations specified in Table 3 are not exceeded. Air flow may be needed to achieve these temperature values (see Section 8.3 and 8.3.1). Operation at case temperatures above these values may adversely affect the drives ability to meet specifications.

The MTBF specification for the drive is based on operating in an environment that ensures that the case temperatures specified in Table 3 are not exceeded. Occasional excursions to drive ambient temperatures of 122°F (50°C) or 41°F (5°C) may occur without impact to specified MTBF. Air flow may be needed to achieve these temperatures (see Section 8.3.1). Continual or sustained operation at case temperatures above these values may degrade MTBF.

To confirm that the required cooling for the electronics and HDA is provided, place the drive in its final mechanical configuration, perform random write/read operations. After the temperatures stabilize, measure the case temperature of the components listed in Table 3 (see note [2]).

The maximum allowable HDA case temperature is 60°C. Operation of the drive at the maximum case temperature is intended for short time periods only. Continuous operation at the elevated temperatures will reduce product reliability.

Table 3: PCBA and HDA temperatures

Items in Figure 8	Maximum allowable case temperature (°C) operating	Maximum allowable case [3] temperatures (°C) to meet MTBF spec.
HDA [2]	60	45
1	80	60
2	68	48
3	76	56
4	71	51

Notes.

- [1] Section 8.3.1 describes the air-flow patterns used when generating the 1 million hours MTBF guidelines in column 2. Air flow was opposite that shown in Section 8.3.1. Local air velocity was 0.92 m/sec (180 lfpm). Inlet air temperature to the drive was 77°F (25°C), plus 9°F (5°C) temperature rise in the test enclosure (86°F/30°C ambient local to the drive).
- [2] Measure HDA temp at point labeled “HDA” on Figure 8.
- [3] PCB mounted integrated circuit case.

b. Non-operating

–40° to 158°F (–40° to 70°C) package ambient with a maximum gradient of 36°F (20°C) per hour. This specification assumes that the drive is packaged in the shipping container designed by Seagate for use with drive.

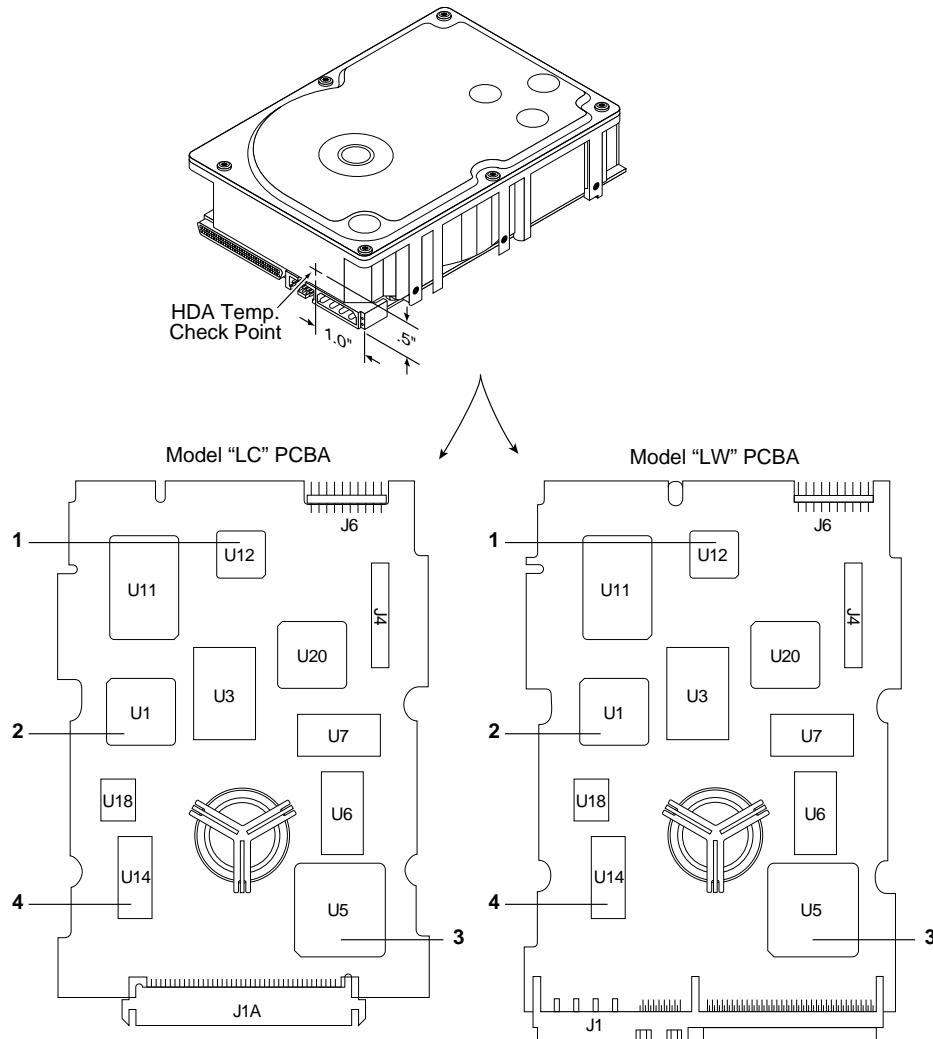

Figure 8. Locations of PCBA components listed in Table 3

6.4.2 Relative humidity

The values below assume that no condensation on the drive occurs.

a. Operating

5% to 95% non-condensing relative humidity with a maximum gradient of 10% per hour.

b. Non-operating

5% to 95% non-condensing relative humidity.

6.4.3 Effective altitude (sea level)

a. Operating

–1,000 to +10,000 feet (–305 to +3,048 meters)

b. Non-operating

–1,000 to +40,000 feet (–305 to +12,210 meters)

6.4.4 Shock and vibration

Shock and vibration limits specified in this document are measured directly on the drive chassis. If the drive is installed in an enclosure to which the stated shock and/or vibration criteria is applied, resonances may occur internally to the enclosure resulting in drive movement in excess of the stated limits. If this situation is apparent, it may be necessary to modify the enclosure to minimize drive movement.

The limits of shock and vibration defined within this document are specified with the drive mounted by any of the four methods shown in Figure 9, and in accordance with the restrictions of Section 8.4. Orientation of the side nearest the LED may be up or down.

6.4.4.1 Shock

a. Operating—normal

The drive, as installed for normal operation, shall operate error free while subjected to intermittent shock not exceeding 5.0 Gs at a maximum duration of 11 msec (half sinewave). Shock may be applied in the X, Y, or Z axis.

b. Operating—abnormal

Equipment, as installed for normal operation, does not incur physical damage while subjected to intermittent shock not exceeding 10 Gs at a maximum duration of 11 msec (half sinewave). Shock occurring at abnormal levels may promote degraded operational performance during the abnormal shock period. Specified operational performance will continue when normal operating shock levels resume. Shock may be applied in the X, Y, or Z axis. Shock is not to be repeated more than two times per second.

c. Non-operating

The limits of non-operating shock shall apply to all conditions of handling and transportation. This includes both isolated drives and integrated drives.

The drive subjected to nonrepetitive shock not exceeding 75 Gs at a maximum duration of 11 msec (half sinewave) shall not exhibit device damage or performance degradation. Shock may be applied in the X, Y, or Z axis.

The drive subjected to nonrepetitive shock not exceeding 175 Gs at a maximum duration of 2 msec (half sinewave) does not exhibit device damage or performance degradation. Shock may be applied in the X, Y, or Z axis.

The drive subjected to nonrepetitive shock not exceeding 90 Gs at a maximum duration of 0.5 msec (half sinewave) does not exhibit device damage or performance degradation. Shock may be applied in the X, Y, or Z axis.

d. Packaged

Disc drives shipped as loose load (not palletized) general freight will be packaged to withstand drops from heights as defined in the table below. For additional details refer to Seagate specifications 30190-001 (under 100 lbs/45 kg) or 30191-001 (over 100 lbs/45 Kg).

Package size	Packaged/product weight	Drop height
<600 cu in (<9,800 cu cm)	Any	60 in (1524 mm)
600-1800 cu in (9,800-19,700 cu cm)	0-20 lb (0 to 9.1 kg)	48 in (1219 mm)
>1800 cu in (>19,700 cu cm)	0-20 lb (0 to 9.1 kg)	42 in (1067 mm)
>600 cu in (>9,800 cu cm)	20-40 lb (9.1 to 18.1 kg)	36 in (914 mm)

Drives packaged in single or multipacks with a gross weight of 20 pounds (8.95 kg) or less by Seagate for general freight shipment shall withstand a drop test from 48 inches (1,070 mm) against a concrete floor or equivalent.

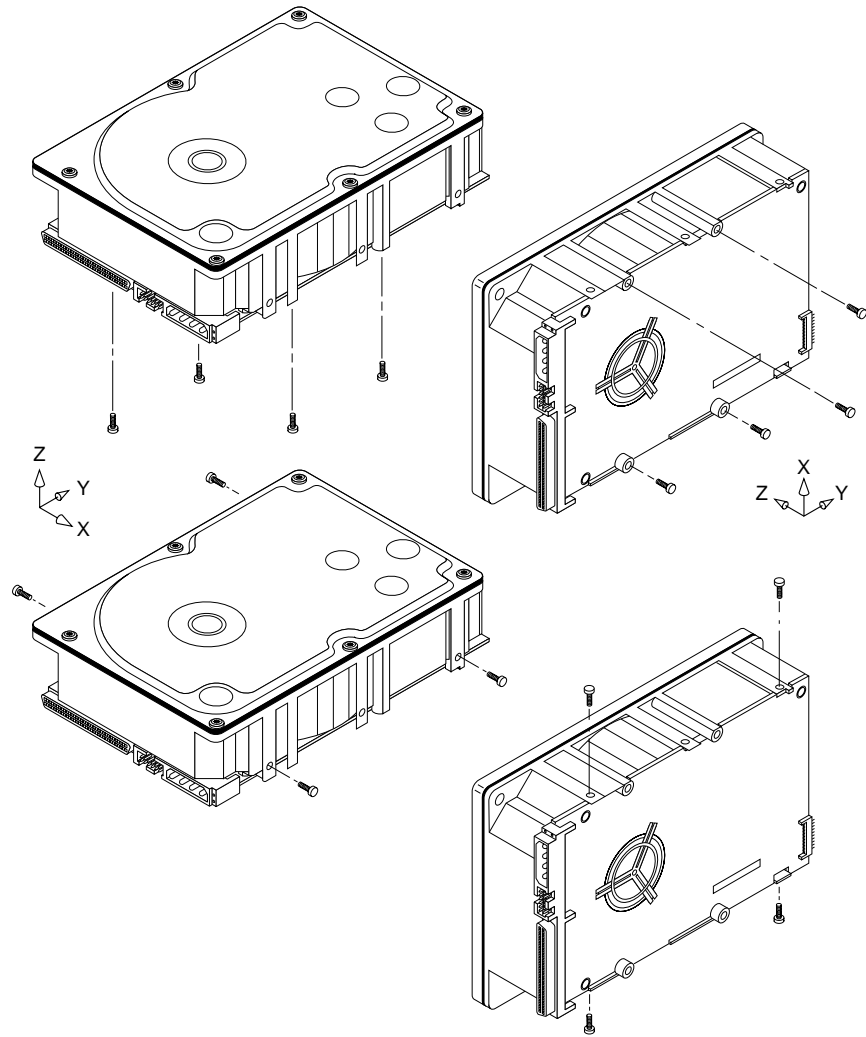

Figure 9. Recommended mounting

6.4.4.2 Vibration

a. Operating - normal

The drive as installed for normal operation, shall comply with the complete specified performance while subjected to continuous vibration not exceeding

5-400 Hz @ 0.5 G

Vibration may be applied in the X, Y, or Z axis.

b. Operating - abnormal

Equipment as installed for normal operation shall not incur physical damage while subjected to periodic vibration not exceeding:

15 minutes of duration at major resonant frequency

5-400 Hz @ 0.75 G (X, Y, or Z axis)

Vibration occurring at these levels may degrade operational performance during the abnormal vibration period. Specified operational performance will continue when normal operating vibration levels are resumed. This assumes system recovery routines are available.

c. Non-operating

The limits of non-operating vibration shall apply to all conditions of handling and transportation. This includes both isolated drives and integrated drives.

The drive shall not incur physical damage or degraded performance as a result of continuous vibration not exceeding

5-22 Hz @ 0.040 inches (1.02 mm) displacement

22-400 Hz @ 2.00 G

Vibration may be applied in the X, Y, or Z axis.

6.4.5 Air cleanliness

The drive is designed to operate in a typical office environment with minimal environmental control.

6.4.6 Acoustics

Sound power during idle mode shall be 4.7 bels typical when measured to ISO 7779 specification.

There will not be any discrete tones more than 10 dB above the masking noise on typical drives when measured according to Seagate specification 30553-001. There will not be any tones more than 24 dB above the masking noise on any drive.

6.4.7 Electromagnetic susceptibility

See Section 2.1.2.

6.5 Mechanical specifications

The following nominal dimensions are exclusive of the decorative front panel accessory. However, dimensions of the front panel are shown in figure below. Refer to Figures 10 and 11 for detailed mounting configuration dimensions. See Section 8.4, "Drive mounting."

Height:	1.6 in	40.64 mm
Width:	4.000 in	101.6 mm
Depth:	5.75 in	146.05 mm
Weight:	2.0 pounds	0.907 kilograms

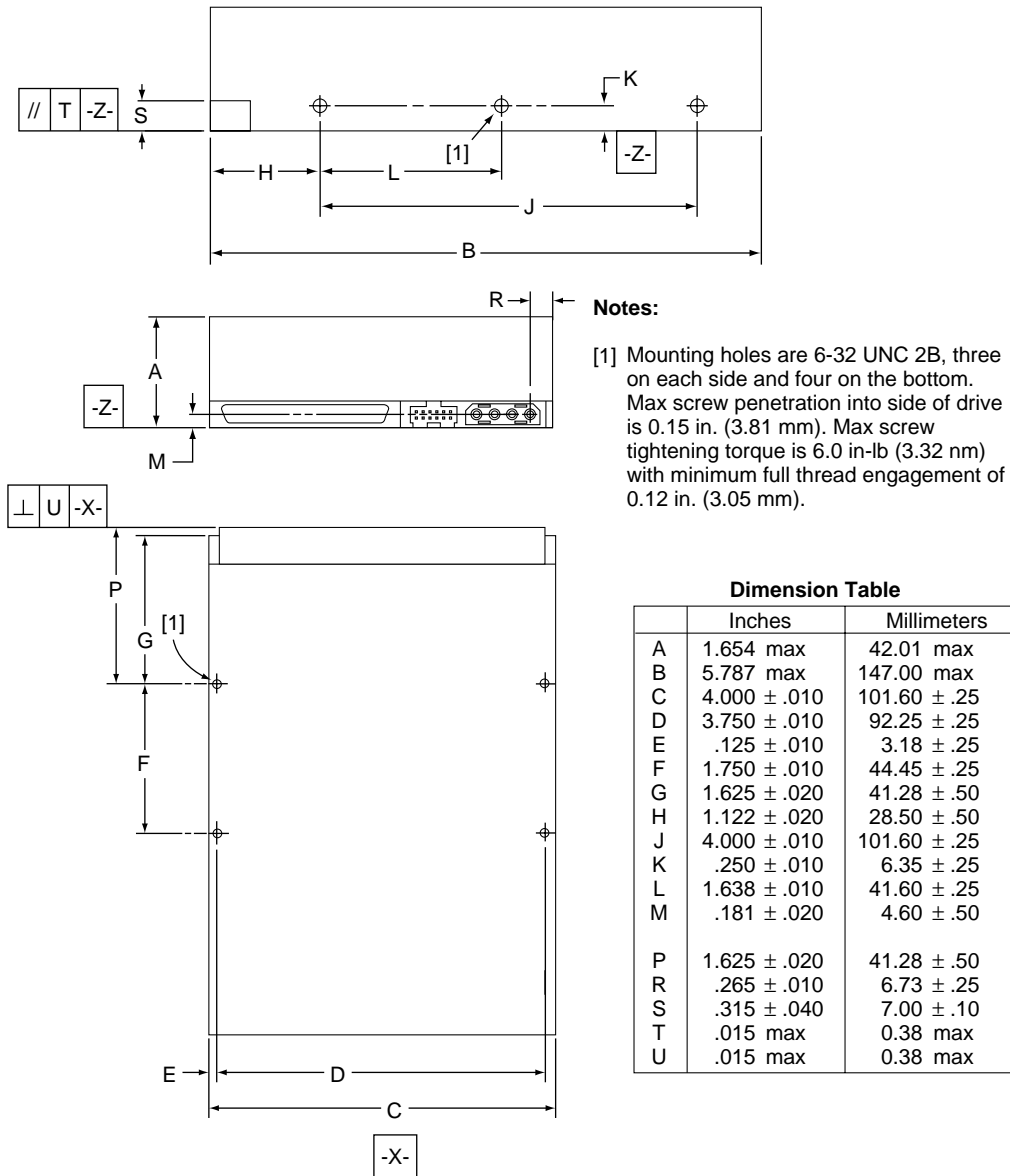

Figure 10. ST136403LW mounting configuration dimensions

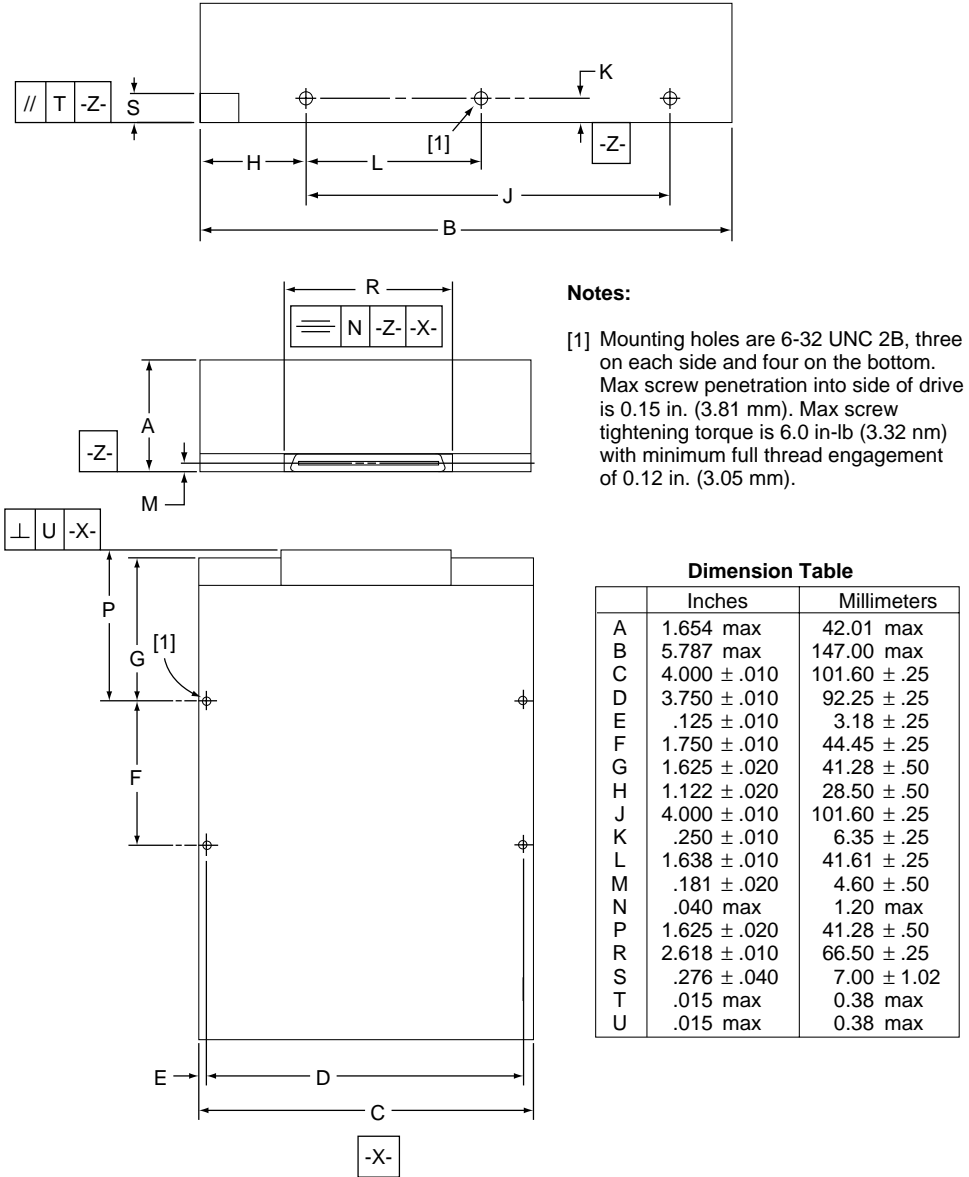

Figure 11. ST136403LC mounting configuration dimensions

7.0 Defect and error management

The drive, as delivered, complies with this specification. The read error rate and specified storage capacity are not dependent upon use of defect management routines by the host (initiator).

Defect and error management in the SCSI system involves the drive internal defect/error management and SCSI systems error considerations (errors in communications between Initiator and the drive). Tools for use in designing a defect/error management plan are briefly outlined in this section, with references to other sections where further details are given.

7.1 Drive internal defects

During the initial drive format operation at the factory, media defects are identified, tagged as being unusable, and their locations recorded on the drive primary defects list (referred to as the "P" list and also as the ETF defect list). At factory format time, these known defects are also reallocated, that is, reassigned to a new place on the medium and the location listed in the defects reallocation table. The "P" list is not altered after factory formatting. Locations of defects found and reallocated during error recovery procedures after drive shipment are listed in the "G" list (defects growth list). The "P" and "G" lists may be referenced by the initiator using the Read Defect Data command (see Section 5.2.1.2 in the *SCSI Interface Product Manual*, part number 77738479).

7.2 Drive error recovery procedures

Whenever an error occurs during drive operation, the drive, if programmed to do so, performs error recovery procedures to attempt to recover the data. The error recovery procedures used depend on the options previously set up in the error recovery parameters mode page. Error recovery and defect management may involve the use of several SCSI commands, the details of which are described in the *SCSI Interface Product Manual*. The drive implements selectable error recovery time limits such as are required in video applications. For additional information on this, refer to Table 5.2.1-22 in the *SCSI Interface Product Manual* which describes the Mode Select/Mode Sense Error Recovery parameters.

The error recovery scheme supported by the drive provides a means to control the total error recovery time for the entire command in addition to controlling the recovery level for a single LBA. The total amount of time spent in error recovery for a command can be limited via the Recovery Time Limit bytes in the Error Recovery Mode Page. The total amount of time spent in error recovery for a single LBA can be limited via the Read Retry Count or Write Retry Count bytes in the Error Recovery Mode Page.

The drive firmware error recovery algorithms consist of 11 levels for read recoveries and 5 levels for writes.

Table 4 equates the Read and Write Retry Count with the maximum possible recovery time for read and write recovery of individual LBAs. The times given do not include time taken to perform reallocations, if reallocations are performed. Reallocations are performed when the ARRE bit (for reads) or AWRE bit (for writes) is one, the RC bit is zero, and the Recovery Time Limit for the command has not yet been met. Time needed to perform reallocation is not counted against the Recovery Time Limit.

The Read Continuous (RC) bit, when set to one, requests the disc drive to transfer the requested data length without adding delays (for retries or ECC correction) that may be required to insure data integrity. The disc drive may send erroneous data in order to maintain the continuous flow of data. The RC bit should only be used when data integrity is not a concern and speed is of utmost importance. If the Recovery Time Limit or retry count is reached during error recovery, the state of the RC bit is examined. If the RC bit is set, the drive will transfer the unrecovered data with no error indication and continue to execute the remaining command. If the RC bit is not set, the drive will stop data transfer with the last good LBA, and report a "Check Condition, Unrecovered Read Error."

Table 4: Read and write retry count maximum recovery times [1]

Read retry count [1]	Maximum recovery time per LBA (cumulative, msec)	Write retry count	Maximum recovery time per LBA (cumulative, msec)
0	65.7	0	35.8
1	77.6	1	53.7
2	89.6	2	59.7
3	113.4	3	77.6
4	149.3	4	185.1
5	197.0	5 (default)	226.9
6	244.8		
7	334.3		
8	394.0		
9	441.8		
10	549.2		
11	2,009.2		
12 (default)	4,283.8		

[1] These values are subject to change.

Setting these retry counts to a value below the default setting could result in an increased unrecovered error rate which may exceed the value given in this product manual. A setting of zero (0) will result in the drive not performing error recovery.

For example, suppose the Read/Write Recovery page has the RC bit set to 0, read retry count set to 4, and the recovery time limit field (Mode Sense page 01, bytes 10 and 11) set to FF FF hex (maximum). A four LBA Read command is allowed to take up to 209 msec recovery time for each of the four LBAs in the command. If the recovery time limit is set to 00 C8 hex (200 msec decimal) a four LBA read command is allowed to take up to 200 msec for all error recovery within that command. The use of the Recovery Time Limit field allows finer granularity on control of the time spent in error recovery. The recovery time limit only starts counting when the drive is executing error recovery and it restarts on each command. Therefore, each command's total recovery time is subject to the recovery time limit. Note: A recovery time limit of 0 will use the drive's default value of FF FF. Minimum recovery time limit is achieved by setting the Recovery Time Limit field to 00 01.

7.3 SCSI systems errors

Information on the reporting of operational errors or faults across the interface is given in the *SCSI Interface Product Manual*, part number 77738479. Message Protocol System is described in the *SCSI Interface Product Manual*. Several of the messages are used in the SCSI systems error management system. The Request Sense command returns information to the host about numerous kinds of errors or faults. The Receive Diagnostic Results reports the results of diagnostic operations performed by the drive.

Status returned by the drive to the Initiator is described in the *SCSI Interface Product Manual*. Status reporting plays a role in the SCSI systems error management and its use in that respect is described in sections where the various commands are discussed.

8.0 Installation

Note. These drives are designed to be used only on single-ended (SE) or low voltage differential (LVD) buses. Do not install these drives on a high voltage differential (HVD) bus.

The first thing to do when installing a drive is to set the drive SCSI ID and set up certain operating options. This is usually done by installing small shorting jumpers on the pins of connectors J2 and J6 on the PCBA (or J1-Auxiliary on the LW model), or via the drive to host I/O signals on the LC model. Some users connect cables to J6 or J5-Auxiliary and perform the set-up using remote switches.

If your system is “SCAM” (SCSI Configured Auto Magically) compliant, the system assigns the drive SCSI ID over the interface, so there is no need to be concerned about drive SCSI ID. Setting the drive SCSI ID jumpers doesn’t hurt anything, but is not necessary.

If your system is not “SCAM” compliant you do need to set the drive SCSI ID using the ID jumpers.

Configure drive options

For option jumper locations and definitions refer to Figures 12, 13, and 14. Drive default mode parameters are not normally needed for installation. Refer to Section 9.3.2 for default mode parameters if they are needed.

- Ensure that the SCSI ID of the drive is not the same as the host adapter. Most host adapters use SCSI ID 7 because ID 7 is the highest priority on both 8 and 16 bit data buses.
- If multiple devices are on the bus set the drive SCSI ID to one that is not presently used by other devices on the bus.
- If the drive is the only device on the bus, attach it to the end of the SCSI bus cable. The user, system integrator, or host equipment manufacturer must provide external terminators.

Note. For additional information about terminator requirements, refer to Sections 9.8 and 9.9.

- Set all appropriate option jumpers for desired operation prior to power on. If jumpers are changed after power has been applied, recycle the drive power to make the new settings effective.
- Installation instructions are provided by host system documentation or with any additionally purchased drive installation software. If necessary see Section 10 for Seagate support services telephone numbers.
- Do not remove the manufacturer’s installed labels from the drive and do not cover with additional labels, as the manufacturer labels contain information required when servicing the product.

Formatting

- It is not necessary to low level format this drive. The drive is shipped from the factory low level formatted in 512 byte sectors.
- Reformat the drive if a different spare sector allocation scheme is selected.
- High level formatting the drive involves assigning one or more partitions or logical drives to the drive volume. Follow the instructions in the system manuals for the system into which the drive is to be installed.

8.1 Drive ID/option select header

Figures 12 and 13 show views of the drive ID select jumper connectors. Figure 14 shows the option select jumper connector for all models. Figure 12 shows the drive’s J5-auxiliary jumper connector. Both J5-auxiliary and J6 have pins for selecting drive ID and for connecting the remote LED cable. Only one or the other should be used, although using both at the same time would not damage the drive. The notes following the figures describe the functions of the various jumper positions on the connectors J2, J5-Auxiliary and J6. Suggested part number for the jumpers used on J2 is Molex 52747-0211 (Seagate part number 77679052). A bag with the two jumper plug types is shipped with the standard OEM drives.

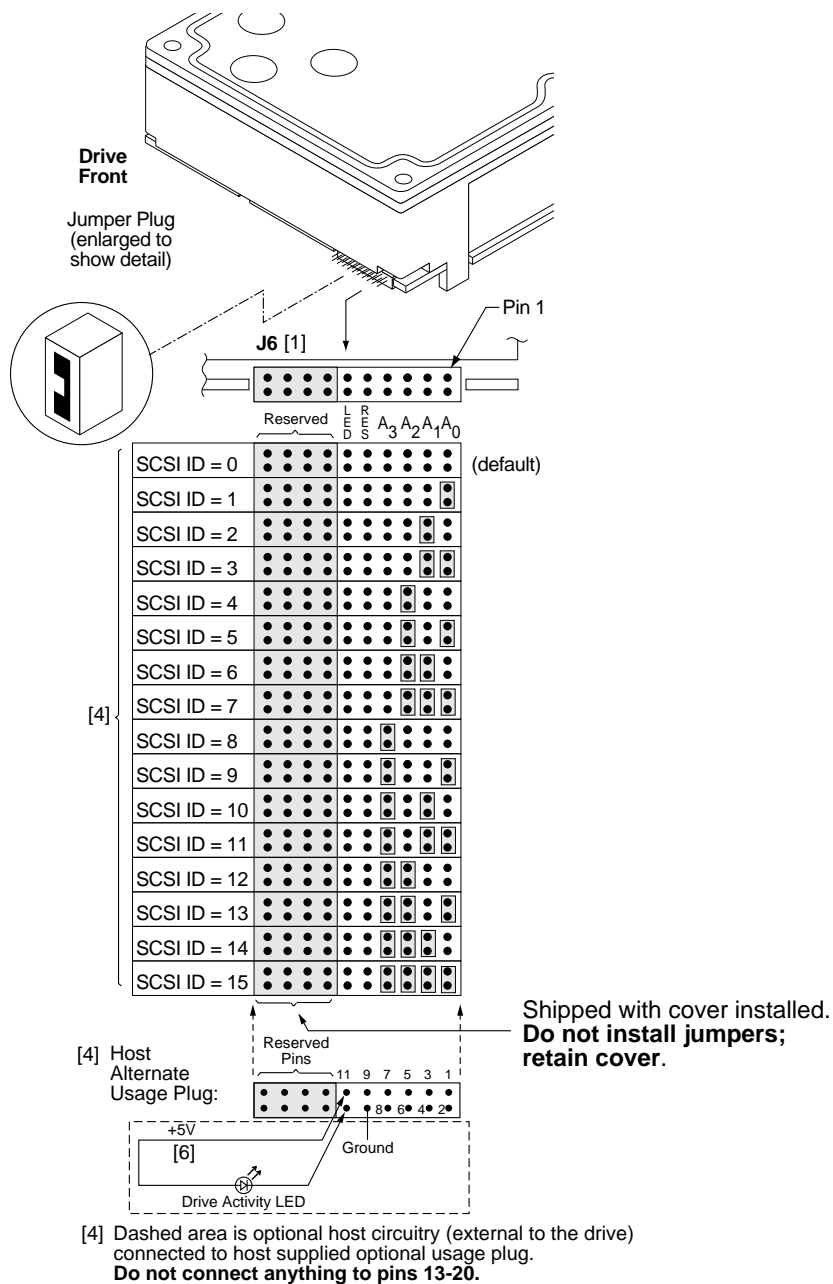

Figure 12. J6 jumper header

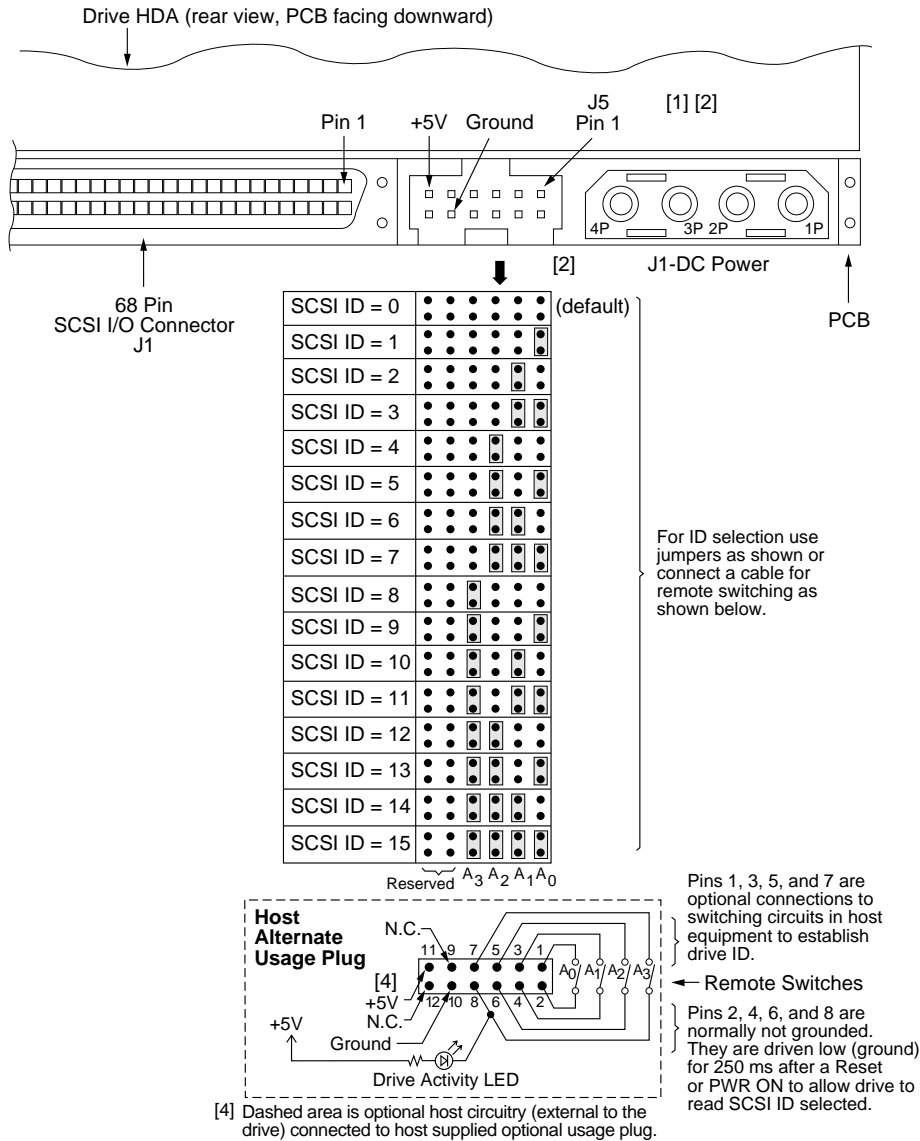

Figure 13. J5 jumper header (on LW models only)

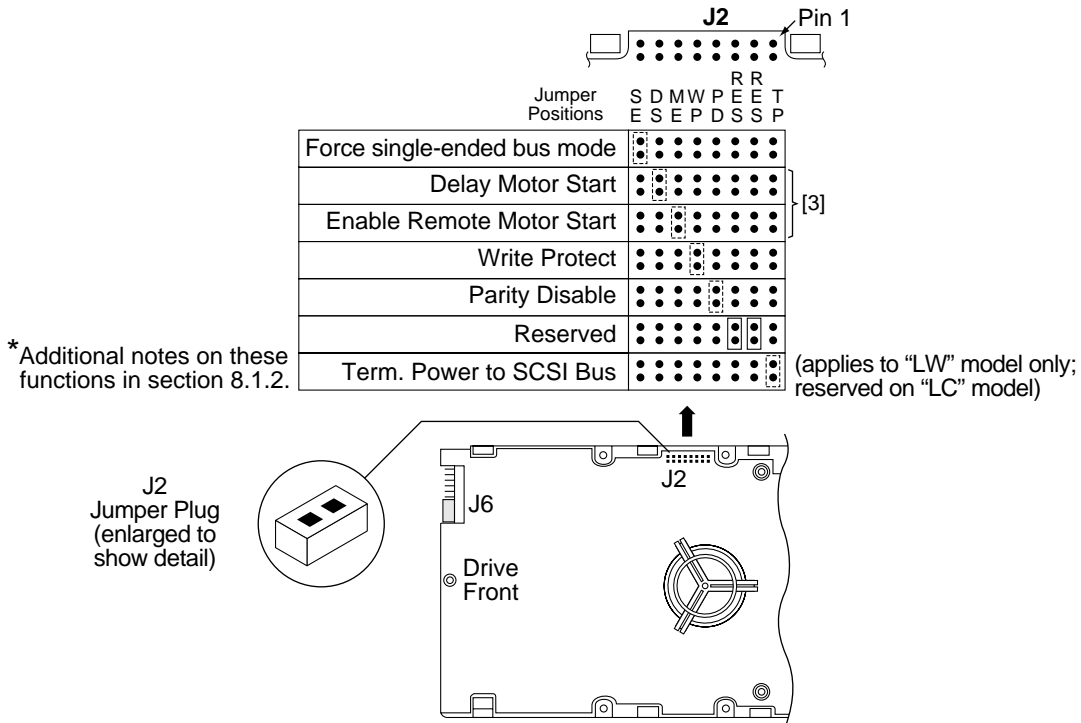

Figure 14. J2 option select header

8.1.1 Notes for Figures 12, 13, and 14.

[1] Notes explaining the functions of the various jumpers on jumper header connectors J2, J5, and J6 are given here and in Section 8.1.2. The term “**default**” means as standard OEM units are configured with a jumper on those positions when shipped from factory. “Off” means no jumper is installed; “On” means a jumper is installed. OFF or ON underlined is factory **default** condition.

The PCBA on LC models does not have connector J5. The J5 connector signals conform to SFF-8009 Revision 2.0, Unitized Connector for Cabled Drives, signal assignments for auxiliary connectors.

[2] These signals are also on 80-pin J1 I/O connector. See Tables 14 and 15.

[3] Voltage supplied by the drive.

8.1.2 Function description

J2

jumper

installation

Jumper function description

SE

On

Forces drive to use single-ended I/O drivers/receivers only.

Off

Drive can operate on the interface in low voltage differential mode or single-ended, depending on the voltage state of the I/O "DIFFSENS" line. **Default** is SE jumper not installed.

DS ME

Off Off

Spindle starts immediately after power up - **Default** setting.

Off On

Drive spindle does not start until Start Unit command received from host.

On Off

Spindle Startup is delayed by SCSI ID times 12 seconds after power is applied, i.e., drive 0 spindle starts immediately when DC power connected, drive 1 starts after 12 second delay, drive 2 starts after 24 second delay, etc.

On On

Drive spindle starts when Start Unit command received from host. Delayed start feature is overridden and does not apply when **ME** jumper is installed.

WP

On

Entire drive is write protected.

Off

Drive is not write protected. **Default** is **WP** jumper not installed.

PD

On

Parity checking and parity error reporting by the drive is disabled.

Off

Drive checks for parity and reports result of parity checking to host.

Default is **PD** jumper not installed.

RES

Off

Reserved jumper position. **Default** is no **RES** jumper installed.

TP1

(Does not apply to "LC" model)

Off

The drive does not supply terminator power to external terminators or to the SCSI bus I/O cable.

On

Drive supplies power to SCSI bus I/O cable. When drives have differential I/O circuits, a jumper on the **TP1** position may be needed to power external terminators (see system documentation). These drives do not have terminator circuits on the drive.

8.2 Drive orientation

The balanced rotary arm actuator design of the drive allows it to be mounted in any orientation. All drive performance characterization, however, has been done with the drive in horizontal (discs level) and vertical (drive on its side) orientations, and these are the two preferred mounting orientations.

8.3 Cooling

Cabinet cooling must be designed by the customer so that the ambient temperature immediately surrounding the drive will not exceed temperature conditions specified in Section 6.4.1, "Temperature." Specific consideration should be given to make sure adequate air circulation is present around the printed circuit board (PCB) to meet the requirements of Section 6.4.1, "Temperature."

8.3.1 Air flow

The rack, cabinet, or drawer environment for the drive must provide heat removal from the electronics and head and disc assembly (HDA). You should confirm that adequate heat removal is provided using the temperature measurement guidelines described in Section 6.4.1.

Forced air flow may be required to keep temperatures at or below the specified case temperatures of Table 3, in which case the drive should be oriented, or air flow directed, so that the least amount of air flow resistance is created while providing air flow to the electronics and HDA. Also, the shortest possible path between the air inlet and exit should be chosen to minimize the travel length of air heated by the drive and other heat sources within the rack, cabinet, or drawer environment.

If forced air is determined to be necessary, possible air-flow patterns are shown in Figure 15. The air-flow patterns are created by one or more fans, either forcing or drawing air as shown in the illustrations. Conduction, convection, or other forced air-flow patterns are acceptable as long as the temperature measurement guidelines of Section 6.4.1 are met.

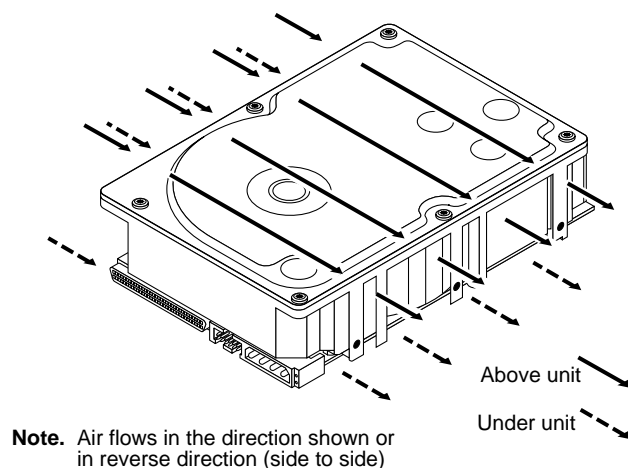
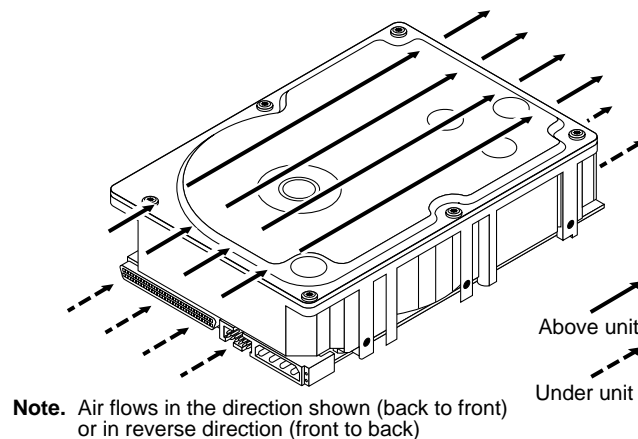

Figure 15. Air flow (suggested)

8.4 Drive mounting

When mounting the drive using the bottom holes (x-y plane in Figure 9) care must be taken to ensure that the drive is not physically distorted due to a stiff non-flat mounting surface. The allowable mounting surface stiffness is 80 lb/in (14.0 N/mm). The following equation and paragraph define the allowable mounting surface stiffness:

$$k * x = F \leq 15\text{lb} = 67\text{N}$$

where 'k' represents the mounting surface stiffness (units of lb/in or N/mm), and 'x' represents the out-of-plane mounting surface distortion (units of inches or millimeters). The out-of-plane distortion ('x') is determined by defining a plane with three of the four mounting points fixed and evaluating the out-of-plane deflection of the fourth mounting point when a known force (F) is applied to the fourth point.

Note. Before mounting the drive in any kind of 3.5-inch to 5.25-inch adapter frame, verify with Seagate Technology that the drive can meet the shock and vibration specifications given herein while mounted in such an adapter frame. Adapter frames that are available may not have a mechanical structure capable of mounting the drive so that it can meet the shock and vibration specifications listed in this manual.

8.5 Grounding

Signal ground (PCBA) and HDA ground are connected together in the drive and cannot be separated by the user. The equipment in which the drive is mounted is connected directly to the HDA and PCBA with no electrically isolating shock mounts. If it is desired for the system chassis to not be connected to the HDA/PCBA ground, the systems integrator or user must provide a nonconductive (electrically isolating) method of mounting the drive in the host equipment.

Increased radiated emissions may result if you do not provide the maximum surface area ground connection between system ground and drive ground. This is the system designer's and integrator's responsibility.

9.0 Interface requirements

This section partially describes the interface requirements as implemented on the drives.

9.1 General description

This section describes in essentially general terms the interface requirements supported by the Cheetah 36. No attempt is made to describe all of the minute details of conditions and constraints that must be considered by designers when designing a system in which this family of drives can properly operate. Seagate declares that the drives operate in accordance with the appropriate ANSI Standards referenced in various places herein, with exceptions as noted herein or in the *Seagate SCSI Interface Product Manual*, part number 77738479.

9.2 SCSI interface messages supported

Table 5 lists the messages supported by the SCSI-2 and SCSI-3 modes of the Cheetah 36 family drives.

Table 5: SCSI messages supported by Cheetah 36 family drives

Message name	Message code	Supported by SCSI-2/3
Abort	06h	Y
Abort-tag	0Dh	Y
Bus device reset	0Ch	Y
Clear ACA	16h	N
Clear queue	0Eh	Y
Command complete	00h	Y
Continue I/O process	12h	Y
Disconnect	04h	Y
Extended messages	01h [1]	Y
Identify	80h-FFh	Y
Ignore wide residue (two bytes)	23h	Y
Initiate recovery	0Fh	N
Initiator detected error	05h	Y
Linked command complete	0Ah	Y
Linked command complete with flag	0Bh	Y
Message parity error	09h	Y
Message reject	07h	Y
Modify data pointer	[1]	N
No operation	08h	Y
Queue tag messages (two bytes)		
ACA	24h	N
Head of queue tag	21h	Y
Ordered queue tag	22h	Y
Simple queue tag	20h	Y
Release recovery	10h	N
Restore pointers	03h	Y
Save data pointer	02h	Y
Synchronous data transfer req.	[1]	Y
Target transfer disable	13h	Y
Terminate I/O process	11h	Y
Wide data transfer request	[1]	Y

Notes.

[1] Extended messages (see the *SCSI Interface Product Manual*, part number 77738479).

9.3 SCSI interface commands supported

Table 6 following lists the SCSI interface commands that are supported in the SCSI-2, and SCSI-3 modes of the drive. Cheetah 36 Family drives can be changed back and forth between SCSI-1 and SCSI-2/SCSI-3 modes using the Change Definition Command. OEM standard drives are shipped set to operate in SCSI-2/SCSI-3 mode.

Table 6: Commands supported by Cheetah 36 family drive

Command name	Command code	Supported by SCSI-2/3
Change definition	40h	Y
Compare	39h	N
Copy	18h	N
Copy and verify	3Ah	N
Format unit [1]	04h	Y
DPRY bit supported		N
DCRT bit supported		Y
STPF bit supported		Y
IP bit supported		Y
DSP bit supported		Y
IMMED bit supported		Y
VS (vendor specific)		N
Inquiry	12h	Y
Date code page (C1h)		Y
Firmware numbers page (C0h)		Y
Implemented operating def page (81h)		Y
Jumper settings page (C2h)		Y
Supported Vital product data page (00h)		Y
Unit serial number page (80h)		Y
Lock-unlock cache	36h	N
Log select	4Ch	Y
PCR bit		Y
DU bit		N
DS bit		Y
TSD bit		Y
ETC bit		N
TMC bit		N
LP bit		N
Log sense	4Dh	Y
Cache statistics page (37h)		Y
Non-medium error page (06h)		Y
Pages supported list (00h)		Y
Read error counter page (03h)		Y
Verify error counter page (05h)		Y
Write error counter page (02h)		Y
Factory log page (3Eh)		Y
Mode select (same pages as Mode Sense 1Ah)	15h	Y [2]
Mode select (10) (same pages as Mode Sense 1Ah)	55h	Y
Mode sense	1Ah	Y [2]
Caching parameters page (08h)		Y
Control mode page (0Ah)		Y
Disconnect/reconnect (02h)		Y

Table 6: Commands supported by Cheetah 36 family drive (Continued)

Command name	Command code	Supported by SCSI-2/3
Error recovery page (01h)		Y
Format page (03h)		Y
Information exceptions control page (1Ch)		Y
Notch and Partition Page (0Ch)		N
Power condition page (1Ah)		Y
Rigid disc drive geometry page (04h)		Y
Unit attention page (00h)		Y
Verify error recovery page (07h)		Y
Xor Control page (10h)		N
Mode sense (10) (same pages as Mode Sense 1Ah)	5Ah	Y
Prefetch	34h	N
Read	08h	Y
Read buffer (modes 0, 2, 3 supported)	3Ch	Y
Read capacity	25h	Y
Read defect data (10)	37h	Y
Read defect data (12)	B7h	Y
Read extended	28h	Y
DPO bit supported		Y
FUA bit supported		Y
Read long	3Eh	Y
Reassign blocks	07h	Y
Receive diagnostic results	1Ch	Y
Supported diagnostics pages (00h)		Y
Translate page (40h)		Y
Release	17h	Y
Release (10)	57h	Y
Request sense	03h	Y
Actual retry count bytes		Y
Extended sense		Y
Field pointer bytes		Y
Reserve	16h	Y
3rd party reserve		Y
Extent reservation		N
Reserve (10)	56h	Y
3rd part reserve		Y
Extent reservation		N
Rezero unit	01h	Y
Search data equal	31h	N
Search data high	30h	N
Search data low	32h	N
Seek	0Bh	Y
Seek extended	2Bh	Y
Send diagnostics	1Dh	Y
Supported diagnostics pages (00h)		Y
Translate page (40h)		Y
Set limits	33h	N
Start unit/stop unit (spindle ceases rotating) (1Ch)	1Bh	Y

Table 6: Commands supported by Cheetah 36 family drive (Continued)

Command name	Command code	Supported by SCSI-2/3
Synchronize cache	35h	Y
Test unit ready	00h	Y
Verify	2Fh	Y
BYTCHK bit		Y
Write	0Ah	Y
Write and verify	2Eh	Y
DPO bit		Y
Write buffer (modes 0, 2, supported)	3Bh	Y
Firmware download option (modes 5, 7 supported) [3]		Y
Write extended	2Ah	Y
DPO bit		Y
FUA bit		Y
Write long	3Fh	Y
Write same	41h	Y
PBdata		N
LBdata		N
XDRead	52h	N
XDWrite	50h	N
XPWrite	51h	N

[1] The drive can format to any even number of bytes per sector from 512 to 4,096

[2] Tables 8 show how individual bits are set and which are changeable by the host.

[3] **WARNING:** A power loss during flash programming can result in firmware corruption. This usually makes the drive inoperable.

Table 7 lists the Standard Inquiry command data that the drive should return to the initiator per the format given in the *SCSI Interface Product Manual*, part number 77738479, Section 5.1.1.3.

Table 7: Cheetah 36 family drive Standard Inquiry data

Bytes	Data (HEX)																
0-15	00	00	[02] ¹	[12] ²	8B	00	[01]	[3E]	53	45	41	47	41	54	45	20	VENDOR ID
16-31	53	54	[31]	[33]	[36]	[34]	[30]	[33]	[4C]	[57] ³	20	20	20	20	20	20	PRODUCT ID
32-47	R#	R#	R#	R#	S#	S#	S#	S#	S#	S#	S#	S#	00	00	00	00	
48-63	00	00	00	00	00	00	00	00	00	00	00	00	00	00	00	00	
64-79	00	00	00	00	00	00	00	00	00	00	00	00	00	00	00	00	
80-95	00	00	00	00	00	00	00	00	00	00	00	00	00	00	00	00	
96-111	00	43	6F	70	79	72	69	67	68	74	20	28	63	29	20	[31]	COPYRIGHT
112-127	[39]	[39]	[38] ⁵	20	53	65	61	67	61	74	65	20	41	6C	6C	20	NOTICE
128-143	72	69	67	68	74	73	20	72	65	73	65	72	76	65	64	20	

[]¹ 01 means SCSI-1 implemented;
02 means SCSI-2/SCSI-3 implemented. Default is 02.

[]² The drive can be changed between these two configurations:
01 means response data in SCSI-1 format and has compatibility with Common Command Set data.
02 means response data in SCSI-2/SCSI-3 format (default is 02).

R# Four ASCII digits representing the last four digits of the product Firmware Release number. This information is also given in the Vital Product Data page C0h, together with servo RAM and ROM release numbers.

S# Eight ASCII digits representing the eight digits of the product serial number.

[]³ Bytes 18 through 25 reflect model of drive. Shown here are hex values for Model ST136403LW.
For "LW" models, bytes 24 and 25 are 4C 57.
For "LC" models, bytes 24 and 25 are 4C 43.

[]⁵ Copyright Year - changes with actual year.

9.3.1 Inquiry Vital Product data

Instead of the standard Inquiry data shown in Table 7, the initiator can request several Vital Product Data pages by setting the Inquiry command EVPD bit to one. The *SCSI Interface Product Manual*, part number 77738479, Section 5.1.1.3.1 lists the Vital Product Data pages and describes their formats. A separate Inquiry command must be sent to the drive for each Vital Product Data page the initiator wants the drive to send back.

9.3.2 Mode Sense data

The Mode Sense command provides a means for the drive to report its operating parameters to the initiator. The drive maintains four sets of Mode parameters, Default values, Saved values, Current values and Changeable values.

Default values are hard coded in the drive firmware that is stored in flash EPROM nonvolatile memory on the drive PCBA. Default values can be changed only by downloading a complete set of new firmware into the flash EPROM. An initiator can request and receive from the drive a list of default values and use those in a Mode Select command to set up new current and saved values, where the values are changeable.

Saved values are stored on the disk media using a Mode Select command. Only parameter values that are allowed to be changed can be changed by this method. See “Changeable values” defined below. Parameters in the saved values list that are not changeable by the Mode Select command get their values from the default values storage.

Current values are volatile values currently being used by the drive to control its operation. A Mode Select command can be used to change these values (only those that are changeable). Originally, they are installed from saved or default values after a power on reset, hard reset, or Bus Device Reset message.

Changeable values form a bit mask, stored in nonvolatile memory, that dictates which of the current values and saved values can be changed by a Mode Select command. A “one” allows a change to a corresponding bit; a “zero” allows no change. For example, in Table 8 refer to Mode page 01, in the row entitled “CHG”. These are hex numbers representing the changeable values for mode page 01. Note that bytes 04, 05, 06, and 07 are not changeable, because those fields are all zeros. If some changeable code had a hex value EF, that equates to the binary pattern 1110 1111. If there is a zero in any bit position in the field, it means that bit is not changeable. Bits 7, 6, 5, 3, 2, 1, and 0 are changeable, because those bits are all ones. Bit 4 is not changeable.

Though the drive always reports non-zero values in bytes 00 and 01, those particular bytes are never changeable.

The Changeable values list can only be changed by downloading new firmware into the flash EPROM.

On standard OEM drives the Saved values are taken from the default values list and stored into the saved values storage location on the media prior to shipping.

When a drive is powered up, it takes saved values from the media and stores them to the current values storage in volatile memory. It is not possible to change the current values (or the saved values) with a Mode Select command before the drive is up to speed and is “ready.” An attempt to do so results in a “Check Condition status being returned.

Note. Because there may be several different versions of drive control firmware in the total population of drives in the field, the Mode Sense values given in the following tables may not exactly match those of some drives.

The following tables list the values of the data bytes returned by the drive in response to the Mode Sense command pages for SCSI-2/SCSI-3 implementation (see the *SCSI Interface Product Manual*, part number 77738479).

Definitions: DEF = Default value. Standard drives are shipped configured this way.
 CHG = Changeable bits; indicates if current and saved values are changeable.

Note. Saved values for OEM drives are normally the same as the default values.

Table 8: Mode sense data, ST136403 values (SCSI-2/3 implementation)

Bytes	00	01	02	03	04	05	06	07	08	09	10	11	12	13	14	15	16	17	18	19	20	21	22	23
Mode Sense Data	9F	00	10	08	04	3D	67	20	00	00	02	00												
Mode Page	<-----Mode Page Headers and Parameter Data Bytes----->																							
01 DEF	81	0a	c0	0b	e8	00	00	00	05	00	ff	ff												
01 CHG	81	0a	ff	ff	00	00	00	00	ff	00	ff	ff												
02 DEF	82	0e	80	80	00	0a	00	00	00	00	00	00	00	00	00									
02 CHG	82	0e	ff	ff	00	00	00	00	00	00	00	00	87	00	00	00								
03 DEF	83	16	02	a5	00	00	00	04	00	00	01	2f	02	00	00	01	00	2c	00	38	40	00	00	00
03 CHG	83	16	00	00	00	00	00	00	00	00	00	00	00	00	00	00	00	00	00	00	00	00	00	00
04 DEF	84	16	00	26	2c	18	00	00	00	00	00	00	00	00	00	00	00	00	00	00	27	20	00	00
04 CHG	84	16	00	00	00	00	00	00	00	00	00	00	00	00	00	00	00	00	00	00	00	00	00	00
07 DEF	87	0a	00	0b	e8	00	00	00	00	00	ff	ff												
07 CHG	87	0a	0f	ff	00	00	00	00	00	00	ff	ff												
08 DEF	88	12	14	00	ff	ff	00	00	ff	ff	ff	ff	80	03	00	00	00	00	00	00				
08 CHG	88	12	b5	00	00	00	ff	ff	ff	ff	00	00	a0[1]	ff	00	00	00	00	00	00				
0A DEF	8a	0a	02	00	00	00	00	00	00	00	00	00												
0A CHG	8a	0a	03	f1	00	00	00	00	00	00	00	00												
1A DEF	9a	0a	00	03	00	00	00	01	00	00	00	04												
1A CHG	9a	0a	00	03	00	00	00	00	00	00	00	00												
1C DEF	9c	0a	00	00	00	00	00	00	00	00	00	01												
1C CHG	9c	0a	8d	0f	ff	ff	ff	ff	ff	ff	ff	ff												
00 DEF	80	02	00	00																				
00 CHG	80	02	77	40																				
Read capacity data																								
	04	3d	67	1f	00	00	02	00																

[1] Although byte 12, bit 7 (a0) is shown as changeable, the FSW function governed by that bit is not implemented by this drive.

9.4 SCSI bus conditions and miscellaneous features supported

Asynchronous SCSI bus conditions supported by the drive are listed below. These conditions cause the SCSI device to perform certain actions and can alter the SCSI bus phase sequence. Other miscellaneous operating features supported are also listed here. Refer to the *SCSI Interface Product Manual*, part number 77738479, for details.

Table 9: SCSI bus conditions and other miscellaneous features

Condition/feature supported by:

SCSI-2/SCSI-3	Conditions or feature
N	Adaptive Caching
Y	Arbitrating System
Y	Asynchronous Data Transfer
N	Asynchronous Event Notification
Y	Attention Condition
N	Auto Contingent Allegiance Condition
Y	Contingent Allegiance Condition
Y	Deferred Error Handling
Y	Disconnect/Reconnect
N	High voltage differential (HVD) interface available
Y	Low voltage differential (LVD) interface available
Y	Parameter Rounding (controlled by the Round bit in Mode Select page 0)
Y	Queue tagging (up to 64 Queue tags supported)
Y	Reporting actual retry count in Extended Sense bytes 15, 16 and 17.
Y	Reset Condition
Y	Segmented Caching
Y	SMP = 1 in Mode Select command needed to save RPL and Rotational Offset bytes (See Table 5.2.1-25 in 77738479)
Y	Synchronous Data Transfer
N	Zero Latency Read

SCSI-2/SCSI-3	Status supported
Y	Good
Y	Check Condition
Y	Condition Met/Good
Y	Busy
Y	Intermediate/Good
Y	Intermediate/Condition Met/Good
Y	Reservation Conflict
Y	Queue Full
N	ACA Active

9.5 Synchronous data transfer

9.5.1 Synchronous data transfer periods supported

Table 10 and Section 9.5.2 list Synchronous Data transfer periods supported by the drive. The data transfer period to be used by the drive and the initiator is established by an exchange of messages during the Message Phase of operation. See the section on message protocol in the *SCSI Interface Product Manual*, part number 77738479.

Table 10: Synchronous data transfer periods

M (decimal)	Transfer period (nanoseconds)	Transfer rate (megatransfers/second)
10	25	40.0 ¹
12	50	20.0
25	100	10.0
50	200	5.0

1. This transfer rate is only allowed when using the LVD interface.

9.5.2 REQ/ACK offset

The maximum value supported by the Cheetah 36 family drives for REQ/ACK offset is 15 (0Fh).

9.6 Physical interface

This section describes the connectors, cables, signals, terminators and bus timing of the DC and SCSI I/O interface. See Section 9.8 and Section 9.9 for additional terminator information.

Figures 16 and 17 show the locations of the DC power connector, SCSI interface connector, drive select headers, and option select headers.

Details of the physical, electrical and logical characteristics are given in sections following, while the SCSI operational aspects of Seagate drive interfaces are given in the *SCSI Interface Product Manual*, part number 77738479.

9.6.1 DC cable and connector

ST136403LW drives receive DC power through a 4 pin connector (see Figure 18 for pin assignment) mounted at the rear of the main PCBA. Recommended part numbers of the mating connector are listed below, but equivalent parts may be used.

Type of cable	Connector	Contacts (20-14 AWG)
14 AWG	MP 1-480424-0	AMP 60619-4 (Loose Piece) AMP 61117-4 (Strip)

ST136403LC drives receive power through the 80-pin I/O connector. See Tables 14 and 15.

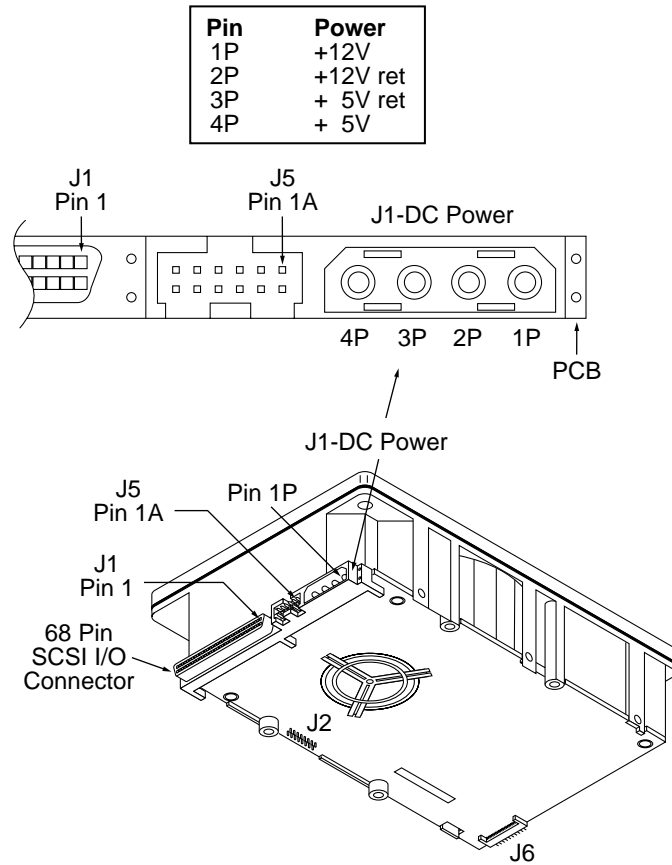

Figure 16. ST136403LW drive physical interface (68-pin J1 SCSI I/O connector)

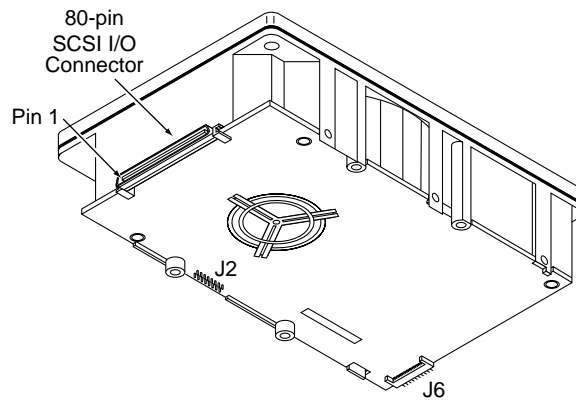

Figure 17. ST136403LC drive physical interface (80-pin J1 SCSI I/O connector)

9.6.2 SCSI interface physical description

The drive models described by this product manual support the physical interface requirements of the SCSI-3 Parallel Interface-2 (SPI-2) standards as defined in American National Standard document X3T10/1142D revision 14, and operate compatibly at the interface with devices that support earlier SCSI-2 and SCSI-3 standards. It should be noted that this is only true if the systems engineering has been correctly done, and if earlier SCSI-2 and SCSI-3 devices respond in an acceptable manner (per applicable SCSI Standards) to reject newer SCSI-3 protocol extensions that they don't support.

The drives documented in this manual support single-ended and low voltage differential physical interconnects (hereafter referred to as SE and LVD, respectively) as described in the ANSI SPI-2 standard. These drives implement driver and receiver circuits that can operate either SE or LVD. However, they cannot switch dynamically between SE and LVD operation.

The drives typically operate on a daisy-chain interface in which other SCSI devices are also operating. Devices on the daisy chain must all operate in the same mode, either SE or LVD, but not a mixture of these. On the interface daisy chain, all signals are common between all devices on the chain, or bus, as it is also called. This daisy chain of SCSI devices must be terminated at both ends with the proper impedance in order to operate correctly. Do not terminate intermediate SCSI devices. In some cases, the SCSI devices at each end have onboard termination circuits that can be enabled by installation of a jumper plug (**TE**) on the device. These termination circuits receive power from either a source internal to the device, or from a line in the interface cable specifically powered for that purpose. ST136403LC and ST136403LW drives do not have onboard termination circuits. Some type of external termination circuits must be provided for these drives by the end user or designers of the equipment into which the drives will be integrated. See Standard X3T10/1142D, sections 6.4 and 6.5 for the maximum number of devices that can successfully operate at various interface transfer rates on SE and LVD daisy chains.

"LC" model drives plug into PCBA or bulkhead connectors in the host. They may be connected in a daisy-chain by the host backplane wiring or PCBA circuit runs that have adequate DC current carrying capacity to support the number of drives plugged into the PCBA or bulkhead connectors. A single 80-pin I/O connector cable cannot support the DC current needs of several drives, so no daisy chain cables beyond the bulkhead connectors should be used. A single drive connected via a cable to a host 80-pin I/O connector is not recommended.

Table 11 shows the interface transfer rates supported by the various drive models defined in this manual.

Table 11: Interface transfer rates supported

Interface type/ drive models		Maximum transfer rate				
		Asynchronous	Fast-5	Fast-10	Fast-20	Fast-40
SE	ST136403LC ST136403LW	yes	yes	yes	yes	no
LVD	ST136403LC ST136403LW	yes	yes	yes	yes	yes

9.6.3 SCSI interface cable requirements

The characteristics of cables used to connect SCSI-3 parallel interface devices are discussed in detail in section 6 of ANSI Standard X3T10/1142D. The cable characteristics that must be considered when interconnecting the drives described in this manual in a SCSI-3 parallel, daisy-chain interconnected system are:

- characteristic impedance (see Section 6.1)
- propagation delay (see Section 6.1)
- cumulative length (see Sections 6.4 and 6.5)
- stub length (see Sections 6.4 and 6.5)
- device spacing (see Sections 6.4 and 6.5)

To minimize discontinuances and signal reflections, cables of different impedances should not be used in the same bus. Implementations may require trade-offs in shielding effectiveness, cable length, number of loads and spacing, transfer rates, and cost to achieve satisfactory system operation. If shielded and unshielded

cables are mixed within the same SCSI bus, the effect of impedance mismatch must be carefully considered. Proper impedance matching is especially important in order to maintain adequate margin at FAST-20 and FAST-40 SCSI transfer rates.

Note. For LVD operation, twisted pair cables are recommended. For LVD Fast-40 operation, twisted pair cables are *strongly* recommended. For Fast-80 operation, twisted pair cables are *required*.

ST136403LC:

The 80-pin connector option is intended for use on drives that plug directly into backplane connector in the host equipment. In such installations, all backplane wiring segments are subject to the electromagnetic concepts presented in Standard X3T10/1142D, section 6. For ST136403LC drives, installations with connectors on cables are not recommended.

9.6.4 Mating connectors

Part numbers for the different type connectors that mate with the various Cheetah 36 I/O connectors are given in the sections following.

9.6.4.1 Mating connectors for ST136403LW drives

The nonshielded cable connector shall be a 68 conductor connector consisting of two rows of 34 male contacts with adjacent contacts 0.050 inch (1.27 mm) apart.

Recommended mating flat cable connector part numbers are:

Amp Model 786096-7	Female, 68-pin, panel mount
Amp Model 786090-7	Female, 68-pin, cable mount
Amp Model 749925-5	(50 mil conductor centers, 28 or 30 AWG wire) Use two, 34 conductor, 50 mil center flat cable with this connector. This type connector can only be used on cable ends. [1]
Amp Model 88-5870-294-5	W/O Strain Relief (25 mil conductor centers, 30 AWG wire). Use either on cable ends or in cable middle section for daisy-chain installations [1].
Amp Model 1-480420-0	Power connector 4 circuit housing
Berg 69307-012	12-position, 2 x 6, 2 mm receptacle housing

[1] See Figure 18.

The drive device connector is a nonshielded 68 conductor connector consisting of two rows of 34 female pins with adjacent pins 50 mils apart. The connector is keyed by means of its shape (see Figure 19).

9.6.4.2 Mating connectors for ST136403LC drives

The nonshielded connector shall be an 80-conductor connector consisting of two rows of 40 contacts with adjacent contacts 50 (1.27 mm) mils apart (see Figure 20). I/O connection using a cable is not recommended. The length and size of the host equipment DC power carrying conductors from the DC power source to the host equipment 80-pin disk drive interface connector(s) should be strictly designed according to proper power transmission design concepts. No possibility for the equipment user to attach an 80-pin cable/connector should be allowed, since the length of the DC power carrying conductors could not be controlled and therefore could become too long for safe power transmission to the drive. Daisy-chain 80-conductor cables should especially not be allowed, since the power-carrying conductors on the 80-conductor interface were not intended to support a series of drives.

To insure that both drive connector and host equipment mating connector mate properly, both drive connector and host equipment mating connector must meet the provisions of "SFF-8046 Specification for 80-pin connector for SCSI Disk Drives."

Recommended mating 80-position PCBA mount connectors:

Straight-in connector		Hot plug version (with ground guide-pin)	
Seagate P/N:	77678703		
Amp US P/N:	2-557103-1	787311-1	with polarization
	or 94-0680-02-1		
Amp US P/N:	2-557103-2	787311-2	without polarization
	or 94-0680-02-2		
Amp Japan P/N:	5-175475-9		

Right-angle to PCBA connectors

Seagate P/N: 77678559 Amp US P/N: 2-557101-1 Amp Japan P/N: 5-175474-9

For additional information call Amp FAX service at 1-800-522-6752.

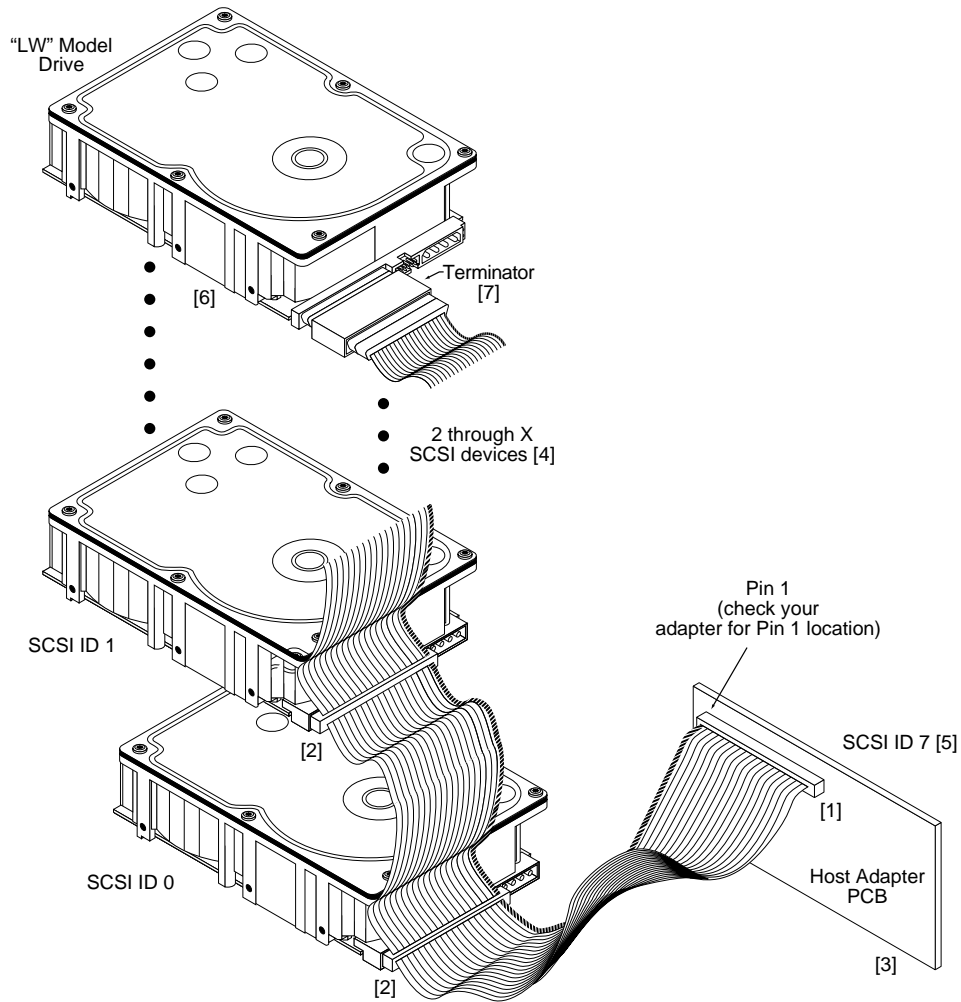

- [1] Closed end type 68-pin connector used. Terminators enabled.
- [2] Open end type (in-line application) connector used.
- [3] Host need not be on the end of the daisy-chain. Another device can be on the end with the terminator, the host having no terminator.
- [4] Total interface cable length must not exceed that specified in ANSI document X3T10/1142D (including host adapter/initiator). The cable length restriction limits the total number of devices allowed.
- [5] SCSI ID7 has highest arbitration priority, then ID15 to ID8 (ID 8 very lowest).
- [6] Last drive on the daisy chain.
- [7] Open-end type 68-pin connector used. If end device, use external terminator and closed-end type 68-pin connector.

Figure 18. SCSI daisy chain interface cabling for LW drives

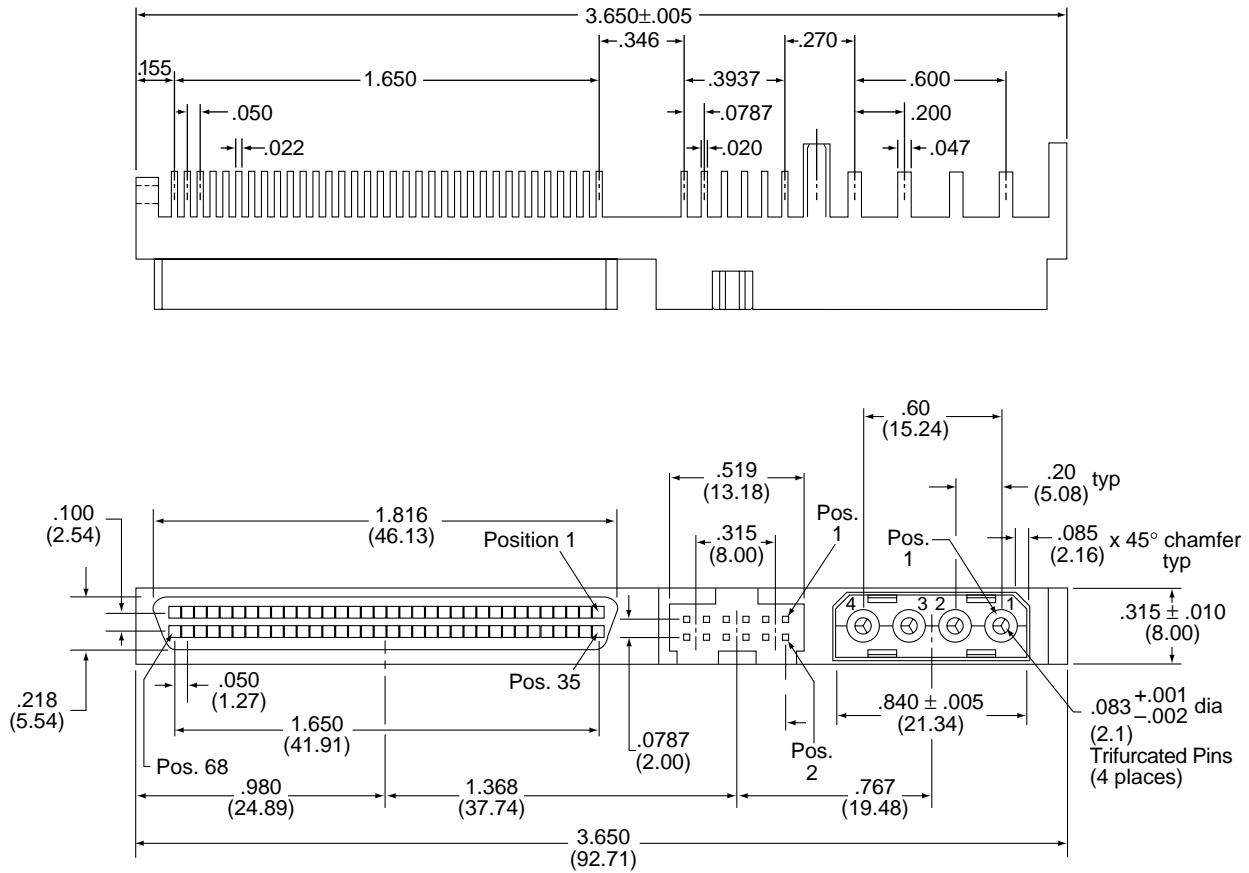

Figure 19. Nonshielded 68 pin SCSI device connector used on LW drives

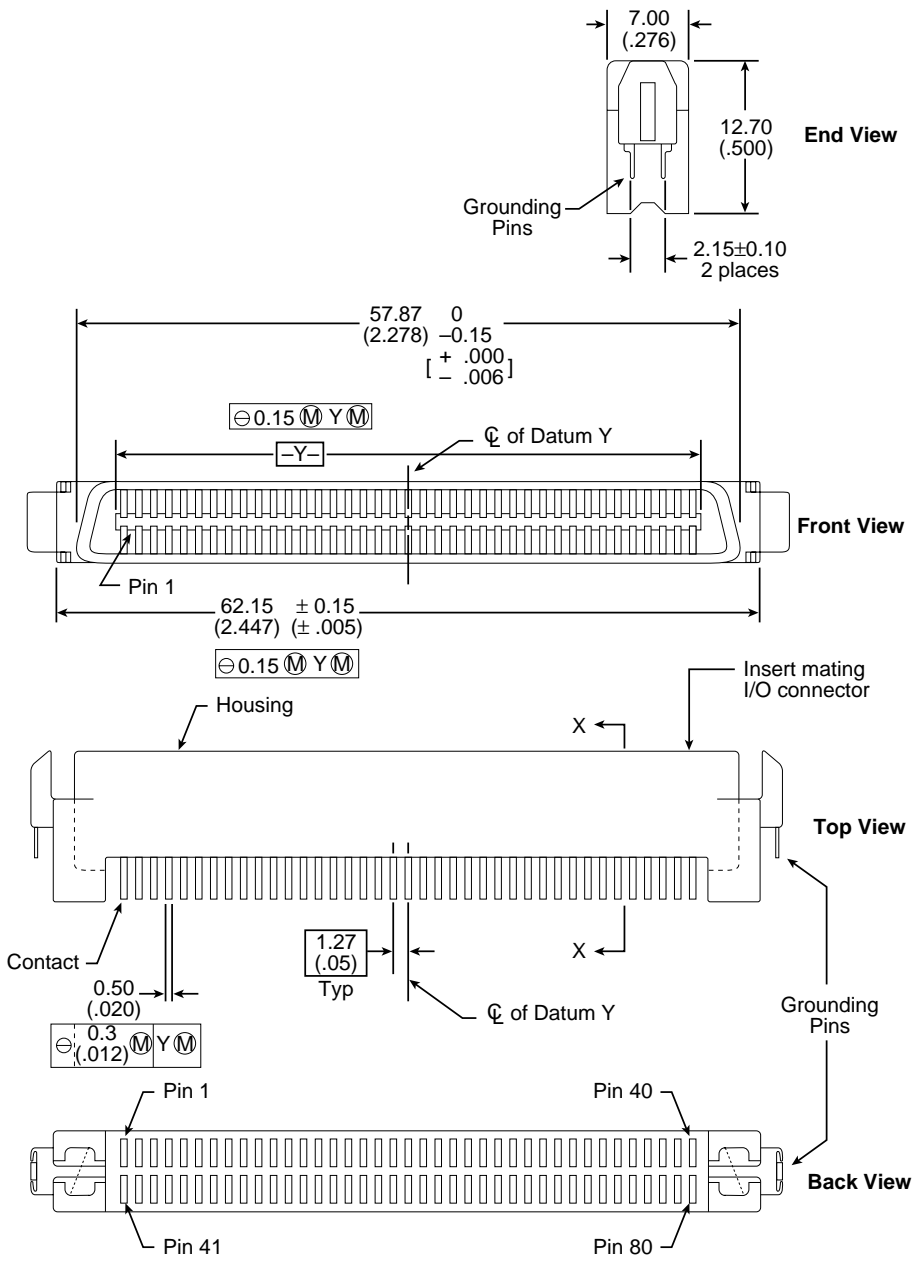

Figure 20. Nonshielded 80 pin SCSI "SCA-2" connector, used on LC drives

Table 12: LW 68-conductor single-ended (SE) P cable signal/pin assignments [13]

Note. A minus sign preceding a signal name indicates that signal is active low.

Signal name [1]	Connector contact number [3]	Connector contact number [3]	Signal name [1]
GND	1	35	-DB12
GND	2	36	-DB13
GND	3	37	-DB14
GND	4	38	-DB15
GND	5	39	-DBP1
GND	6	40	-DB0
GND	7	41	-DB1
GND	8	42	-DB2
GND	9	43	-DB3
GND	10	44	-DB4
GND	11	45	-DB5
GND	12	46	-DB6
GND	13	47	-DB7
GND	14	48	-DBP
GND	15	49	GND
GND	16	50	GND
TermPwr	17	51	TermPwr
TermPwr	18	52	TermPwr
Reserved	19	53	Reserved
GND	20	54	GND
GND	21	55	-ATN
GND	22	56	GND
GND	23	57	-BSY
GND	24	58	-ACK
GND	25	59	-RST
GND	26	60	-MSG
GND	27	61	-SEL
GND	28	62	-C/D
GND	29	63	-REQ
GND	30	64	-I/O
GND	31	65	-DB8
GND	32	66	-DB9
GND	33	67	-DB10
GND	34	68	-DB11

Notes []: See page following Table 15.

Table 13: LW 68-conductor LVD P cable signal/pin assignments [13]

Note. A minus sign preceding a signal name indicates that signal is active low.

Signal name [1]	Connector contact number [3]	Connector contact number [3]	Signal name [1]
+DB12	1	35	-DB12
+DB13	2	36	-DB13
+DB14	3	37	-DB14
+DB15	4	38	-DB15
+DBP1	5	39	-DBP1
+DB0	6	40	-DB0
+DB1	7	41	-DB1
+DB2	8	42	-DB2
+DB3	9	43	-DB3
+DB4	10	44	-DB4
+DB5	11	45	-DB5
+DB6	12	46	-DB6
+DB7	13	47	-DB7
+DBP	14	48	-DBP
Ground	15	49	Ground
DIFFSNS [8]	16	50	Ground
TermPwr	17	51	TermPwr
TermPwr	18	52	TermPwr
Reserved	19	53	Reserved
Ground	20	54	Ground
+ATN	21	55	-ATN
Ground	22	56	Ground
+BSY	23	57	-BSY
+ACK	24	58	-ACK
+RST	25	59	-RST
+MSG	26	60	-MSG
+SEL	27	61	-SEL
+C/D	28	62	-C/D
+REQ	29	63	-REQ
+I/O	30	64	-I/O
+DB8	31	65	-DB8
+DB9	32	66	-DB9
+DB10	33	67	-DB10
+DB11	34	68	-DB11

Notes []: See page following Table 15.

Table 14: LC 80-pin single-ended (SE) I/O connector pin assignments [13]

Note. A minus sign preceding a signal name indicates that signal is active low.

Signal name [1]	Connector contact number [3]	Signal number [3]	Contact name[1]
12 V CHARGE	1	41	12 V GND
12 V	2	42	12 V GND
12 V	3	43	12 V GND
12 V	4	44	MATED 1
NC [10]	5	45	NC [10]
NC [10]	6	46	DIFFSNS [8]
-DB11	7	47	GND
-DB10	8	48	GND
-DB9	9	49	GND
-DB8	10	50	GND
-I/O	11	51	GND
-REQ	12	52	GND
-C/D	13	53	GND
-SEL	14	54	GND
-MSG	15	55	GND
-RST	16	56	GND
-ACK	17	57	GND
-BSY	18	58	GND
-ATN	19	59	GND
-DBP	20	60	GND
-DB7	21	61	GND
-DB6	22	62	GND
-DB5	23	63	GND
-DB4	24	64	GND
-DB3	25	65	GND
-DB2	26	66	GND
-DB1	27	67	GND
-DB0	28	68	GND
-DP1	29	69	GND
-DB15	30	70	GND
-DB14	31	71	GND
-DB13	32	72	GND
-DB12	33	73	GND
+5 V	34	74	MATED 2
+5 V	35	75	5 V GND
+5 V	36	76	5 V GND
NC [10]	37	77	ACTIVE LED OUT [4] [9]
RMT-START [5] [9]	38	78	DLYD-START [6] [9]
SCSI ID (0) [7] [9]	39	79	SCSI ID (1) [7] [9]
SCSI ID (2) [7] [9]	40	80	SCSI ID (3) [7] [9]

Notes []: See page following Table 15.

Table 15: LC 80-pin single-ended (LVD) I/O connector pin assignments [13]

Note. A minus sign preceding a signal name indicates that signal is active low.

Signal name [1]	Connector contact number [3]	Signal number [3]	Contact name[1]
12 V CHARGE	1	41	12 V GND
12 V	2	42	12 V GND
12 V	3	43	12 V GND
12 V	4	44	MATED 1
NC [10]	5	45	NC [10]
NC [10]	6	46	DIFFSNS [8]
-DB11	7	47	+DB11
-DB10	8	48	+DB10
-DB9	9	49	+DB9
-DB8	10	50	+DB8
-I/O	11	51	+I/O
-REQ	12	52	+REQ
-C/D	13	53	+C/D
-SEL	14	54	+SEL
-MSG	15	55	+MSG
-RST	16	56	+RST
-ACK	17	57	+ACK
-BSY	18	58	+BSY
-ATN	19	59	+ATN
-DBP	20	60	+DBP0
-DB7	21	61	+DB7
-DB6	22	62	+DB6
-DB5	23	63	+DB5
-DB4	24	64	+DB4
-DB3	25	65	+DB3
-DB2	26	66	+DB2
-DB1	27	67	+DB1
-DB0	28	68	+DB0
-DBP1	29	69	+DP1
-DB15	30	70	+DB15
-DB14	31	71	+DB14
-DB13	32	72	+DB13
-DB12	33	73	+DB12
+5 V	34	74	MATED 2
+5 V	35	75	5 V GND
+5 V CHARGE	36	76	5 V GND
NC [10]	37	77	ACTIVE LED OUT [4] [9]
RMT_START [5] [9]	38	78	DLYD_START [6] [9]
SCSI ID (0) [7] [9]	39	79	SCSI ID (1) [7] [9]
SCSI ID (2) [7] [9]	40	80	SCSI ID (3) [7] [9]

Notes []: See page following this table.

Notes [] for Tables 12 through 15.

- [1] See Section 9.6.4.1 for detailed electrical characteristics of these signals.
- [2] The conductor number refers to the conductor position when using 0.025-inch (0.635 mm) centerline flat ribbon cable. Other cables types may be used to implement equivalent contact assignments.
- [3] Connector contacts are on 0.050 inch (1.27 mm) centers.
- [4] Front panel LED signal; indicates drive activity for host front panel hard drive activity indicator.
- [5] Asserted by host to enable Motor Start option (enables starting motor via SCSI bus command).
- [6] Asserted by host to enable Delayed Motor Start option (motor starts at power on or after a delay of 12 seconds times drive ID). This and [3] above are mutually exclusive options.
- [7] Binary code on A3, A2, A1 and A0 asserted by host to set up SCSI bus ID in drive.
- [8] GND provides a means for differential devices to detect the presence of a single ended device on the bus. Drive will not operate I/O bus at Ultra2 SCSI data rates if this is grounded.
- [9] Signals [4] through [7] are used in place of installing jumpers and cables on option select connectors J2 and J6. See Section 8.1.1 notes.
- [10] "NC" means no connection.
- [11] The conductor number refers to the conductor position (right to left in Figure 18) when using 0.050 inch (1.27 mm) centerline flat ribbon cable. Other cable types may be used to implement equivalent contact assignments.
- [12] Connector contacts are on 0.100 inch (2.54 mm) centers.
- [13] 8 bit devices which are connected to the 16 data bit LVD I/O shall leave the following signals open: –DB8, –DB9, –DB10, –DB11, –DB12, –DB13, –DB14, –DB15, and –DBP1.
8 bit devices which are connected to the 16 data bit single-ended (SE) I/O shall have the following signals open: DB8, –DB9, –DB10, –DB11, –DB12, –DB13, –DB14, –DB15, and –DBP1.
All other signals should be connected as shown.

9.7 Electrical description

ST136403LW and ST136403LC drives are multimode devices. That is, their I/O circuits can operate as either single-ended or low voltage differential drivers/receivers (selectable using the I/O "DIFFSENS" line).

See ANSI Standard X3T10/1142D for details electrical specifications.

9.7.1 Multimode—SE and LVD alternatives

When the interface "DIFFSENS" line is between +0.35 V and +0.5 V, the drive interface circuits operate single-ended and up to and including 20 M transfers/s (Fast-20 or Ultra SCSI). When "DIFFSENS" is between +0.7 V and +1.9 V, the drive interface circuits operate low voltage differential and up to and including 40 M transfers/s or less (Fast-40 or Ultra2 SCSI).

This multimode design does not allow dynamically changing transmission modes. Drives must operate only in the mode for which the installation and interface cabling is designed. Multimode I/O circuits used by these drives do not operate at high voltage differential levels and should never be exposed to high voltage differential environments unless the common mode voltages in the environment are controlled to safe levels for single-ended and low voltage differential devices (see the ANSI SPI-2 specification X3T10/1142D).

Multimode signals

Multimode circuit SE alternative signal characteristics are the same as described elsewhere in Section 9.7.1. The SE alternative for these circuits is selected as described above. SE cables and termination must be used.

"LC" and "LW" model drives do not have onboard terminators. The Multimode signal lines (either SE or LVD) should be terminated with 110 ohm active terminator circuits at each end of the total cable. Termination of the I/O lines must be provided for by the Host equipment designers or end users.

The SE and differential alternatives are mutually exclusive.

Output characteristics

Each signal (V_s) driven by LVD interface drivers shall have the following output characteristics when measured at the disc drive connector:

Steady state Low level output voltage* = $-0.95\text{ V} = < V_s = < -1.55\text{ V}$ (signal negation/logic 0)
 Steady state High level output voltage* = $-0.95\text{ V} = < V_s = < 1.55\text{ V}$ (signal assertion/logic 1)
 Differential voltage = $\pm 0.6\text{ V}$ minimum with common-mode voltage ranges $0.700\text{ V} = < V_{cm} = < 1.800\text{ V}$.

*These voltages shall be measured between the output terminal and the SCSI device's logic ground reference.

The output characteristics shall additionally conform to EIA RS-485.

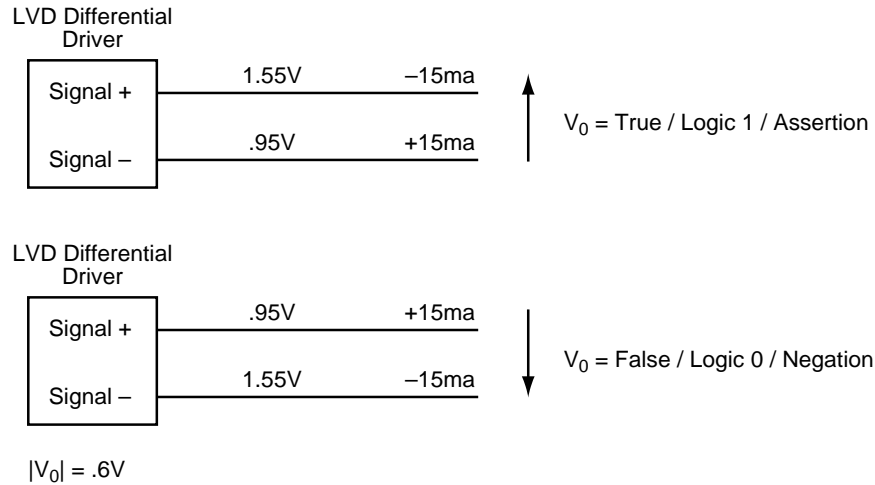

Figure 21. LVD output signals

Input characteristics

Each signal (V_s) received by LVD interface receiver circuits shall have the following input characteristics when measured at the disk drive connector:

Steady state Low level output voltage* = $0.030\text{ V} = < V_s = < 3.6\text{ V}$ (signal negation/logic 0)
 Steady state High level output voltage* = $-3.6\text{ V} = < V_s = < -0.030\text{ V}$ (signal assertion/logic 1)
 Differential voltage = $\pm 0.30\text{ V}$ minimum with common-mode voltage ranges $0.700\text{ V} = < V_{cm} = < 1.800\text{ V}$.
 (X3T10/1142D revision 13, p. 152)

*These voltages shall be measured between the output terminal and the SCSI device's logic ground reference.

Input characteristics shall additionally conform to EIA RS-485-983.

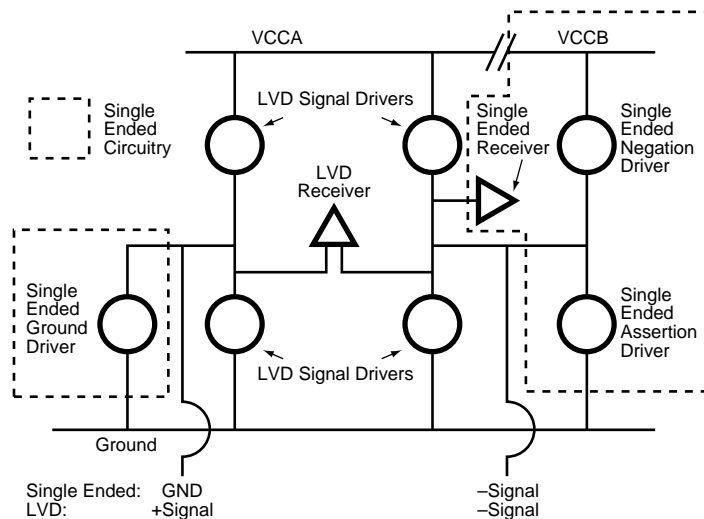

Figure 22. Typical SE-LVD alternative transmitter receiver circuits

9.7.1.1 Single-ended drivers/receivers

The maximum total cable length allowed with drives using single-ended I/O driver and receiver circuits depends on several factors. Table 16 lists the maximum lengths allowed for different configurations of drive usage. These values are from the SPI-2 document. All device I/O lines must have equal to or less than 25 pf capacitance to ground, measured at the beginning of the stub.

Table 16: Cable characteristics for single-ended circuits

I/O transfer rate	Maximum number of devices on the bus	maximum cable length allowed	Transmission line impedance	
			REQ/ACK	Other signals
≤10M transfers/s	16 (wide SCSI bus)	6 meters (19.7 ft)	90 ± 6 Ohms	90 ± 10 Ohms
≤20M transfers/s	4 (wide SCSI bus)	3 meters (9.8 ft)	90 ± 6 Ohms	90 ± 10 Ohms
≤20M transfers/s	8 (wide SCSI bus)	1.5 meters (4.9 ft)	90 ± 6 Ohms	90 ± 10 Ohms

A stub length of no more than 0.1 meter (0.33 ft) is allowed off the mainline interconnection with any connected equipment. The stub length is measured from the transceiver to the connection to the mainline SCSI bus.

Single-ended I/O cable pin assignments for LW drives are shown in Table 13.

Single-ended I/O pin assignments for the LC model are shown in Table 14. The LC model does not require an I/O cable. It is designed to connect directly to a back panel connector.

9.7.1.2 Low voltage differential I/O circuits

The maximum total cable length for use with drives using LVD I/O drivers and receiver circuits is 12 meters (39.37 ft.). A stub length of no more than 0.1 meter is allowed off the mainline interconnection with any connected equipment. LVD I/O pin assignments for LW model drives are shown in tables 12 and 13. LVD I/O pin assignments for LC model drives are shown in tables 14 and 15.

9.7.1.3 General cable characteristics

A characteristic impedance of 100 ohm + 10% is recommended for unshielded flat or twisted pair ribbon cable. However, most available cables have a somewhat lower characteristic impedance. To Minimize discontinuities and signal reflections, cables of different impedances should not be used in the same bus. Implementations may require tradeoffs in shielding effectiveness, cable length, the number of loads, transfer rates, and cost to achieve satisfactory system operation. If shielded and unshielded cables are mixed within the same SCSI bus, the effect of impedance mismatch must be carefully considered. Proper impedance matching is especially important in order to maintain adequate margin at fast SCSI transfer rates.

9.8 Terminator requirements

Caution: These drives do not have onboard internal terminators. The user, systems integrator or host equipment manufacturer must provide a terminator arrangement external to the drive when termination is required. For LW drives, terminator modules can be purchased that plug between the SCSI I/O cable and the drive I/O connector or on the end of a short I/O cable stub extending past the last cable connector. LC drives are designed to be plugged into a backpanel connector without cabling.

9.9 Terminator power

LW drives

You can configure terminator power from the drive to the SCSI bus or have the host adaptor or other device supply terminator power to the external terminator. See Section 8.1 for illustrations that show how to place jumpers for this configuration.

LC drives

These drives cannot furnish terminator power because no conductors in the 80-pin I/O connector are devoted to terminator power.

9.10 Disc drive SCSI timing**Table 17: Disc drive SCSI timing**

These values are not current Cheetah 36 values, but are listed for information only.

Description	Waveform symbol [1]	Waveform table [1]	Typical timing
Target Select Time (no Arbitration)	T00	N/A	<1 μ s
Target Select Time (with Arbitration)	T01	4.5-1,2	1.93 μ s
Target Select to Command	T02	4.5-1	3.77 μ s
Target Select to MSG Out	T03	4.5-2	1.57 μ s
Identify MSG to Command	T04	4.5-3	3.36 μ s
Command to Status	T05	4.5-5	Command Dependent
Command to Data (para. In)	T06	4.5-9	Command Dependent
Command to Data (para. Out)	T07	4.5-10	Command Dependent
Command to Data (Write to Data Buffer)	T08	4.5-10	Command Dependent
Command to Disconnect MSG	T09	4.5-6	Command Dependent
Disconnect MSG to Bus Free	T10	4.5-6,14	0.52 μ s
Disconnect to Arbitration (for Reselect) This measures disconnected CMD overhead	T11	4.5-6	Command Dependent
Target win Arbitration (for Reselect)	T12	4.5-7	3.00 μ s
Arbitration to Reselect	T13	4.5-7	1.60 μ s
Reselect to Identify MSG In	T14	4.5-7	1.39 μ s
Reselect Identify MSG to Status	T15	4.5-8	Command Dependent
Reselect Identify MSG to Data (media)	T16	4.5-11	Command Dependent
Data to Status	T17	4.5-15	Command Dependent
Status to Command Complete MSG	T18	4.5-5,8,15	0.98 μ s
Command Complete MSG to Bus Free	T19	4.5-5,8,15	0.51 μ s
Data to Save Data Pointer MSG	T20	4.5-14	4.00 μ s
Save Data Pointer MSG to Disconnect MSG	T21	4.5-14	0.79 μ s
Command Byte Transfer	T22	4.5-4	0.04 μ s
Next Command Byte Access:		4.5-4	
Next CDB Byte Access (Byte 2 of 6)	T23.6.2	4.5-4	0.58 μ s
Next CDB Byte Access (Byte 3 of 6)	T23.6.3	4.5-4	0.12 μ s
Next CDB Byte Access (Byte 4 of 6)	T23.6.4	4.5-4	0.12 μ s
Next CDB Byte Access (Byte 5 of 6)	T23.6.5	4.5-4	0.12 μ s
Next CDB Byte Access (Byte 6 of 6)	T23.6.6	4.5-4	0.12 μ s
Next CDB Byte Access (Byte 2 of 10)	T23.10.2	4.5-4	0.59 μ s
Next CDB Byte Access (Byte 3 of 10)	T23.10.3	4.5-4	0.11 μ s \pm 1 μ s
Next CDB Byte Access (Byte 4 of 10)	T23.10.4	4.5-4	0.12 μ s \pm 1 μ s
Next CDB Byte Access (Byte 5 of 10)	T23.10.5	4.5-4	0.11 μ s \pm 1 μ s
Next CDB Byte Access (Byte 6 of 10)	T23.10.6	4.5-4	0.11 μ s \pm 1 μ s
Next CDB Byte Access (Byte 7 of 10)	T23.10.7	4.5-4	0.13 μ s \pm 1 μ s
Next CDB Byte Access (Byte 8 of 10)	T23.10.8	4.5-4	0.12 μ s \pm 1 μ s
Next CDB Byte Access (Byte 9 of 10)	T23.10.9	4.5-4	0.12 μ s \pm 1 μ s

Table 17: Disc drive SCSI timing (Continued)

These values are not current Cheetah 36 values, but are listed for information only.

Description	Waveform symbol [1]	Waveform table [1]	Typical timing
Next CDB Byte Access (Byte 10 of 10)	T23.10.10	4.5-4	0.12 μ s \pm 1 μ s
Data In Byte Transfer (parameter)	T24	4.5-12	0.04 μ s
Data Out Byte Transfer (parameter)	T25	4.5-13	0.04 μ s
Next Data In Byte Access (parameter)	T26	4.5-12	0.12 μ s
Next Data Out Byte Access (parameter)	T27	4.5-13	0.12 μ s
Data In Byte Transfer (media) [2]	T28	4.5-12	0.04 μ s
Data Out Byte Transfer (media) [2]	T29	4.5-13	0.04 μ s
Next Data In Byte access (media [2])	T30	4.5-12	0.12 μ s
Next Data Out Byte access (media [2])	T31	4.5-13	0.12 μ s
MSG IN Byte Transfer	T32	4.5-5,7,8,14,15	0.04 μ s
MSG OUT Byte Transfer	T33	4.5-2	0.04 μ s
STATUS Byte Transfer	T34	4.5-5,8,15	0.04 μ s
Synchronous Data Transfer Characteristics:			
Request Signal Transfer Period [3]	–	–	various (800 ns max)

Notes.

- [1] See the *SCSI Interface Product Manual*, part number 77738479, Section 4.5
 [2] Maximum SCSI asynchronous interface transfer rate is given in Section 4.2.3 of this manual.
 [3] Synchronous Transfer Period is determined by negotiations between an Initiator and a Drive. The Drive is capable of setting periods as given in Section 9.5. See also Sections 3.1.5.2 and 3.5.3.2 of the *SCSI Interface Product Manual*, for a description of synchronous data transfer operation.

9.11 Drive activity LED

The following table provides drive activity LED status.

Table 18: Drive activity LED status

Spindle status	Command status	LED status
Spinning up with DC power applied	N/A	On until spinup is complete
Spun down	Start Unit	On while processing the command
Powered down by removal of DC power	N/A	Off due to absence of power
Spun up	Stop Unit	On while processing the command
Spun down	No command activity	Off
Spun down	Write/Read Buffer	On while processing the command
Spun down	SCSI Bus Reset	On while processing the reset
Spun down	Test Unit Ready	On while processing the command
Spun up	No command activity	Off
Spun up	Write/Read	On while processing the command
Spun up	SCSI Bus Reset	On while processing the reset
Spun up	Test Unit Ready	On while processing the command
Spun up	Format with Immediate option on	On while the command is initially processed
Spun up	Format without Immediate	LED toggles on/off on each cylinder boundary

10.0 Seagate Technology support services

Online Services

Internet

For online information about Seagate products, visit www.seagate.com or e-mail your disc or tape questions to:

Presales Support:

Disc: http://www.seagate.com/support/email/email_presales.shtml or DiscPresales@Seagate.com

Tape: http://www.seagate.com/support/email/email_tape_presales.shtml or
Tape_Sales_Support@Seagate.com

Technical Support:

Disc: http://www.seagate.com/support/email/email_disc_support.shtml or DiscSupport@Seagate.com

Tape: http://www.seagate.com/support/email/email_tape_support.shtml or TapeSupport@Seagate.com

SeaBOARD[®] is a computer bulletin board system that contains information about Seagate disc and tape drive products and is available 24 hours daily. Set your communications software to eight data bits, no parity and one stop bit (8-N-1). This service is available worldwide.

Automated Services

SeaFONE[®] (1-800-SEAGATE) is Seagate's toll-free number (1-800-732-4283) to access our automated self-help services. Using a touch-tone phone, you can find answers to service phone numbers, commonly asked questions, troubleshooting tips and specifications for disc drives and tape drives 24 hours daily. International callers can reach this service by dialing +1-405-936-1234.

SeaFAX[®] is Seagate's automated FAX delivery system. Using a touch-tone phone, you can obtain technical support information by return FAX 24 hours daily. This service is available worldwide.

Presales Support

Our Presales Support staff can help you determine which Seagate products are best suited for your specific application or computer system.

Seagate Express

You can purchase select tape products and tape accessories through Seagate Express 24 hours daily by calling 1-800-531-0968 or by faxing your order to: +1-972-481-4812.

Technical Support

If you need help installing your drive, consult your dealer. Dealers are familiar with their unique system configurations and can help you with system conflicts and other technical issues. If you need additional help, you can talk to a Seagate technical support specialist. Before calling, note your system configuration and drive model number (ST####).

SeaTDD[™] (+1-405-936-1687) is a telecommunications device for the deaf (TDD). You can send questions or comments 24 hours daily and exchange messages with a technical support specialist from 8:00 A.M. to 12:15 P.M. and 1:30 P.M. to 6:00 P.M. (central time) Monday through Friday.

Customer Service (CSO)

Warranty Repair

Seagate offers worldwide customer support for Seagate drives. Seagate direct OEM, Distribution and System Integrator customers should contact their Seagate service center representative for warranty information. Other customers should contact their place of purchase.

Authorized Service Centers

If you live outside the US, you can contact an Authorized Service Center for service or repair.

USA/Canada/Latin America Support Services

Presales Support

Disc: 1-877-271-3285 or +1-405-936-1210 FAX: +1-405-936-1683
Tape: 1-800-626-6637 or +1-714-641-2500 FAX: +1-714-641-2410

Technical Support (SeaFONE)

1-800-SEAGATE or +1-405-936-1234 (for specific product phone number)
 FAX: *Disc:* +1-405-936-1685; *Tape:* +1-405-936-1683

SeaFAX 1-800-SEAGATE
SeaTDD +1-405-936-1687
SeaBOARD *Disc:* +1-405-936-1600; *Tape:* +1-405-936-1630

Warranty Repair

USA 1-800-468-3472 FAX: +1-405-949-6740
 Mexico and Latin America +1-405-949-7758 FAX: +1-405-949-6738

Authorized Service Centers

Brazil
MA Informatica +55-21-516-6649 FAX: +55-21-516-5280

Canada
*Memofix** +1-905-660-4936 FAX: +1-905-660-4951
*Adtech** +1-905-812-8099 or 1-800-624-9857 FAX: +1-905-812-7807

European Support Services

For European customer support, dial the toll-free number for your specific country for presales support, technical support, SeaFAX and warranty repair.

If your country is not listed here, dial our European call center at +31-20-316-7222 from 8:30 A.M. to 5:00 P.M. (European central time) Monday through Friday. The European call center is located in Amsterdam, The Netherlands.

Call Center

Austria	0 800-20 12 90
Belgium	0 800-74 876
Denmark	80 88 12 66
France	0 800-90 90 52
Germany	0 800-182 6831
Ireland	1 800-55 21 22
Italy	1 677 90 695
Netherlands	0 800-732 4283
Norway	800-113 91
Poland	00 800-311 12 38
Spain	900-98 31 24
Sweden	0 207 90 073
Switzerland	0 800-83 84 11
Turkey	00 800-31 92 91 40
United Kingdom	0 800-783 5177

SeaBOARD

Germany +49-89-1409331

*Authorized Service Centers

Fax Services—All European Countries

Presales/Technical Support/Warranty Repair 31-20-653-3513

Africa/Middle East Support Services

For presales, technical support, warranty repair and FAX services in Africa and the Middle East, dial our European call center at +31-20-316-7222 from 8:30 a.m. to 5:00 p.m. (European central time) Monday through Friday, or send a FAX to +31-20-653-3513. The European call center is located in Amsterdam, The Netherlands.

Asia/Pacific Support Services***Technical Support***

Australia	+61-2-9725-3366	FAX: +61-2-9725-4052
Hong Kong	+852-2368 9918	FAX: +852-2368 7173
Japan	—	FAX: +81-3-5462-2979
Singapore	+65-488-7584	FAX: +65-488-7528
Taiwan	+886-2-2514-2237	FAX: +886-2-2715-2923

SeaFAX

Australia +61-2-9756-5170

Warranty Repair

Japan	+81-3-5462-2904	FAX: +81-3-5462-2979
Asia/Pacific and Australia	+65-485-3595	FAX: +65-488-7503

Index

Symbols

+5 and +12 volt supplies 19

Numerics

68 conductor connector 52
 68-pin connector 53
 80 conductor connector 52
 80 conductor interface 52
 80 pin connector option 52
 80 pin I/O connector 58, 59

A

AC power 19
 access time 9
 accessories 8
 acoustics 27
 activity indicator 60
 activity LED 64
 actuator 7, 38
 actuator assembly 5
 address 10
 air circulation 38
 air cleanliness 27
 air flow 23, 38
 suggested 38
 air inlet 38
 altitude 24
 altitude and atmospheric pressure 23
 ambient 24
 ambient temperature 23, 38
 ANSI SCSI documents 4
 arbitration priority 53
 asynchronous interface transfer rate 64
 audible noise 3
 Australia/New Zealand Standard 4
 automatic retry 13
 automatic shipping lock 5
 average idle current 19
 average latency 7
 average rotational latency 9, 10

B

background processing 7
 backward compatibility 5
 bits/inch 9
 buffer 10, 11, 12
 buffer segment 11, 12
 buffer-full 11
 buffer-full ratio 11
 bulkhead connector 51
 bus device reset message 46
 bytes per sector 44

bytes/surface 9
 bytes/track 9

C

cabinet cooling 38
 cable 49
 cache 10, 11, 12
 cache buffer 7
 cache miss 11
 cache mode 10
 cache operation 10
 cache operation hit 12
 cache segment 11
 caching write data 11
 Canadian Department of Communications 3
 capacities 8
 capacity, drive, programmable 8
 case temperature 23
 CE Marking 3
 change definition command 42
 changeable bit 47
 changeable value 46
 check condition 46
 circuits 61
 class B limit 3
 command 10, 42
 command descriptor block (CDB) 10
 command queuing 7
 condensation 23, 24
 conducted noise immunity 19, 20
 connect/disconnect 10
 connector 49
 connector contact 60
 consecutive read operation 12
 contiguous blocks of data 12
 continuous vibration 27
 controller 10
 controller overhead 9
 controller self test 20
 cooling 38
 C-Tick Marking 3
 current 20
 current limiting 20
 current profile 20
 current profile (LVD mode) 21
 current profile (SE mode) 21
 current requirements 19
 current value 46, 47
 cylinder boundary 12

D

daisy-chain 20, 51, 53
 80 conductor 52
 data correction 13
 data transfer period 49
 data transfer protocol 7
 data transfer rate 9

- DC cable and connector 49
- DC current 51
- DC power 10, 13, 37, 49
- DC power carrying conductor 52
- DC power connector 49
- DC power requirements 19
- DC power source 52
- dedicated landing zone 5
- default 36, 37
- default mode parameter 33
- default value 46, 47
- defect/error management 31
- delayed motor start option 19, 60
- delayed start 37
- depot repair 15
- depot repair philosophy 15
- diagnostics 20
- differential I/O circuit 37
- differentiating features 5
- dimensions 28
- disable read ahead 12
- disc access 10
- disc media 9
- disc rotational speed 9
- disconnect/reconnect 11
 - control 11
 - specification 11
- discontinuity (DISC) bit 12
- DRA bit 12
- drive 27
- drive activity 60
- drive activity LED 64
- drive capacity 9
 - programmable 8
- drive default mode parameter 33
- drive failure 14
- drive firmware 46
- drive ID 33
- drive ID select jumper connector 33
- drive ID/option select header 33
- drive interface connector 52
- drive internal 20
- drive internal defects and errors 31
- drive malfunction 14
- drive mounting 28, 39
 - constraints 13
- drive orientation 38
- drive power 33
- drive primary defects list 31
- drive SCSI timing 63
- drive select header 49
- drive spindle 37
- drive transfer 11
- drive volume 33
- drive warranty 15
- dynamic spindle brake 7

E

- ECC 13
- ECC correction capability 7
- electrical characteristics 49, 60
- electromagnetic compatibility 3
- electromagnetic interference (EMI) 13
- electromagnetic susceptibility 27
- embedded servo 7
- EMC compliance 3
- EMI requirements 3
- environment 38
- environmental control 27
- environmental interference 13
- environmental limits 23
- environmental requirements 13
- EPROM 46
- equipment malfunction 13
- error 13
- error management system 32
- error rate 13
- error rate calculation 13
- error recovery 31
- ETF defect list 31
- European Union requirements 3
- EVPD bit 45
- execution time 10
- extended messages 41

F

- fault status 13
- FCC rules and regulations 3
- field repair 15
- firmware 46
- flat ribbon cable 60
- flaw reallocation 10
- format 44
- format command 9
- format time 10
- formatted 8
- formatting 33
- front panel 28
- front panel LED 60
- FSW function 47

G

- gradient 24
- ground return 19
- grounding 39

H

- hard reset 46
- hardware error 13
- HDA 5, 15, 23, 38, 39
 - temperature 23
- head and disc assembly. *See* HDA

heat removal 38
 heat source 38
 high level format 33
 host 12, 31, 37, 44, 51, 53
 host adapter 33
 adapter/initiator 53
 host backplane wiring 51
 host equipment 39, 52
 DC power 52
 host I/O signal 33
 host system 33
 host system malfunction 13
 host/drive operational interface 13
 hot plug 7, 15
 humidity 23, 24

I

I/O connector 51
 identified defect 31
 idle condition 22
 Input characteristics 61
 inquiry command 45
 inquiry vital product data 45
 installation 33
 installation guide 8
 installation instructions 33
 instantaneous current peak 19
 integrated Ultra1/Ultra2 SCSI controller 7
 interface cable length 53
 interface data 9
 interface requirements 41
 interface timing 13
 interleave 7
 internal data rate 9

J

J1-auxiliary 33
 jumper 8, 33, 36, 37, 60
 jumper function description 37
 jumper header 36
 jumper plug type 33

L

landing zone 7
 LB 11
 LED 64
 logical 10
 logical block 10, 11, 12
 logical characteristics 49
 logical segment (mode select page 08h) 10
 low level format 33
 low voltage differential (LVD) drivers and receivers 7
 LVD 60, 61
 LVD interface receiver circuits 61
 LVD output signals 61

M

magnetoresistive heads 5
 mating connector 49, 52
 mating flat cable connector 52
 maximum current requirements 20
 maximum operating current 19
 maximum starting current 19
 ME jumper 37
 mean time between failure. *See* MTBF
 media 7, 46
 media defect 13
 media defect induced error 13
 medium error 13
 message protocol 49
 message protocol system 32
 messages
 SCSI interface 41
 miscellaneous features 48
 mode page 01 46
 mode page 08h 10
 mode parameter 46
 page 08h 12
 mode select command 10, 11, 46
 mode select page 08h 12
 mode sense command 46, 47
 mode sense command page 08h 11
 mode sense data 46
 mode sense value 46
 model number table 5
 motor start command 10
 motor start delay option 60
 motor start option 10, 19, 60
 mounting configuration 28
 mounting configuration dimensions 28, 29
 mounting constraints 13, 39
 mounting point 39
 mounting surface 39
 mounting surface distortion 39
 mounting surface stiffness 39
 MR heads 5
 MTBF 13, 14, 23
 multimode drivers and receivers 7
 multiple segment 11
 multi-segmented cache control 10

N

noise 20
 audible 3
 non-operating 24, 25, 27
 temperature 24
 non-operating vibration 27
 nonshielded 68 conductor connector 52

O

office environment 27
 operating 24, 25, 27

operating environment 14
 operating option 33
 operating parameter 46
 operator intervention 13
 option jumper 33
 option jumper location 33
 option select header 49
 option select jumper 33
 options 8
 orientation 10, 25, 38
 out-of-plane deflection 39
 out-of-plane distortion 39
 Output characteristics 60

P

package size 25
 package test specification 4
 packaged 25
 parity 37
 parity checking 37
 parity error 37
 partition or logical drive 33
 PCB 15, 36, 38
 temperature 23
 PCBA 33, 39, 46, 49, 51, 53
 PCBA circuit run 51
 PD jumper 37
 peak bits/inch 9
 peak starting current 19
 performance characteristics 9
 performance degradation 25
 peripheral I/O cable 20
 physical buffer space 10
 physical characteristics 49
 physical damage 27
 physical interface 49, 50
 physically contiguous blocks of data 12
 power 19, 20, 37
 power connector 19, 20
 power control switch 10
 power dissipation 22
 power distribution 3
 power sequencing 20
 power supply voltage 13
 power-carrying conductor 52
 power-on 33, 60
 power-on operating hours 14
 power-on reset 46
 power-up 20, 37
 power-up hours 14
 power-up 10, 11, 12
 prefetch (read look-ahead) 10, 12
 prefetch ceiling field 12
 prefetch data 12
 prefetch field 12
 prefetch hit 12
 prefetch mode 10

prefetch of contiguous blocks 12
 prefetch operation 10, 12
 prefetch segmented cache control 10
 preventive maintenance 13, 15
 printed circuit board. *See* PCB
 PRML read channel electronics 5
 product data page 45
 programmable drive capacity 8

R

radio interference regulations 3
 read 10
 read command 10, 11, 12
 read data 11
 read error 13
 read error rate 13, 31
 read operation 11
 read retry count 31
 read/write head 9
 ready 46
 receive diagnostic results 32
 receiver circuits 61
 recommended mounting 26
 recoverable seek error 13
 reference documents 4
 regulation 19
 relative humidity 24
 reliability 7
 reliability and service 14
 reliability specifications 13
 remote switch 33
 repair facility 15
 repair information 17
 REQ/ACK offset 49
 request sense command 32
 request sense information 14
 resonance 25
 retrieved data 11

S

S.M.A.R.T. 7, 16
 safe power transmission 52
 safety 3
 saved value 46, 47
 SCAM 7, 33
 SCSI
 commands 42
 format commands 13
 interface data transfer rate 9
 messages 41
 SCSI bus cable 33
 SCSI bus condition 48
 SCSI bus ID 60
 SCSI bus phase sequence 48
 SCSI command 31
 SCSI I/O connector 50
 SCSI ID 33, 37

SCSI interface 10, 13, 51
 SCSI interface cable 51
 SCSI interface commands supported 42
 SCSI interface connector 49
 SCSI interface data 9
 SCSI Interface Product Manual 3, 4, 5
 SCSI systems error 32
 SCSI systems error consideration 31
 SCSI systems error management 32
 SCSI-1 mode 42
 SCSI-2/SCSI-3 47
 SCSI-2/SCSI-3 mode 42
 SE 60
 Seagate support service 33
 sector 11
 sector interleave 9
 sector size 8
 sector sizes 10
 seek error 13
 seek positioning error 13
 segment 10, 11
 segment number 11
 self-contained 11
 Self-Monitoring Analysis and Reporting Technology.
 See S.M.A.R.T.
 SE-LVD alternative 61
 sense key 13
 sequential read operations 12
 service
 life 13, 15
 philosophy 15
 tools 15
 servo data 5
 shielding 3
 shipping 17
 shipping container 24
 shock 25
 and vibration 25
 shock mount 39
 signal ground 39
 single unit shipping pack 8
 single-ended (SE) drivers and receivers 7
 single-ended interface circuit 22
 site installation 15
 software interleave 12
 spare part 15
 spindle 20
 spindle startup 37
 standard day 23
 standards 3
 start motor command 19
 start unit command 37
 start/stop time 10
 status 32
 stop spindle 10
 stop time 10
 storage capacity 31
 straight-in connector 53

strict bit in Mode page 00h 11
 supply voltage 19
 support services 65
 synchronous data transfer 49
 synchronous data transfer operation 64
 synchronous data transfer period 49
 synchronous transfer period 64
 system chassis 39
 system recovery procedures 13

T

technical support services 65
 temperature 10, 23, 38
 ambient 23
 case 23
 gradient 23
 non-operating 24
 PCB and HDA 23
 regulation 3
 See also cooling
 termination 20
 terminator enable jumper TE 53
 terminator power 62
 terminator requirements 33, 62
 TP1 position 37
 tracks/inch 9
 tracks/surface, total 9
 transfer period 49
 transmitter receiver circuits 61
 typical access time 10

U

Ultra SCSI 5
 Ultra/Ultra2 SCSI controller 7
 Ultra2 SCSI 5
 Ultra2 SCSI interface 5, 7
 unformatted 8
 unrecoverable condition 13
 unrecoverable error 13
 unrecoverable seek error 14
 Unrecoverable write error 13

V

vibration 25, 27
 vital product data 45
 volatile memory 46
 voltage 10, 19

W

warranty 7, 17
 wet bulb temperature 23
 wide Ultra2 SCSI interface 5
 WP jumper 37
 wrap-around 11
 write caching 11
 write error 13

unrecoverable 13
write operation 11
write protect 37
write retry count 31

Z

zoned bit recording (ZBR) 7



Seagate Technology, Inc.

920 Disc Drive, Scotts Valley, California 95066-4544, USA

Publication Number: 83329440, Rev. B, Printed in USA